

Intuit Booth

Available at
pCon
PLANNER

Phonebooth

Design: Iseasi



You need to make a call. But you'd rather the whole office didn't listen in. Booth provides a quiet oasis, so you can focus on your conversation, without distractions.

We saw an opportunity to make the basic phone booth a much more pleasant place to be. If you've spent time in cramped and claustrophobic phone booths before, you'll marvel at how Booth opens up the space. You can be part of the open-plan space, while still having access to the focus and privacy you need at various points of your day. And its rocking and rotating seat gives you room to move, without banging your elbows on the walls every 5 seconds.

Booth harnesses technology and design to provide an intuitive space for your special task. With sound absorbing upholstery and acoustic panels, Booth dampens noise from every direction. Its motion sensor fresh air ventilation system and adjustable LED lighting help you create exactly the environment you work well in. While its wheels mean you can relocate it to anywhere in your office.



Concentration Zone

Enjoy a room that feels bigger on the inside

Find the peace you need

Take calls without disturbing your team

PRODUCT INFORMATION

Acoustics

Sound absorption class A

Movable

On four wheels underneath, floor adjusters are integrated for levelling

Integrated ventilation

Airflow rate: when occupied 40l/s; stand-by mode, after 5 mins no occupancy 27 l/s

Accessories

Bar height perch, 360° swivel and rocking

Electrical outlet

Integrated electrical outlet

Warranty

5 years

Sustainability

Based on principles of the circular economy

Test & Certification

Sound absorption class B



STANDARD MATERIALS

Structure

High-quality plywood, painted black

Outside

Soft upholstered panels covered with any felt fabric

Inside

Ceiling and wall panels covered with certified acoustic and fire-retardant felt and fabric

Floor

Carpet tile in a fishbone pattern

Glass door and back wall

442 laminated and tempered clear glass with sound control PVB interlayer

Bar height perch

Durable HR-foam, fabric; powder-coated matt metal legs; tilting base

Fabric upholstery

Choose any felt from **Intuit Standard felt selection**

Additional information

As part of after-sales service we offer the change of cover fabric and all other components if needed

Utilitas Wind office in Tallinn, Estonia. Photo: Märt Lillesiim



INSIDE COVER MATERIALS

Walls

Pressed felt

Dark Grey



Other finishing options available on request.

Floor

Carpet tile

Grey



ELECTRICAL OUTLET

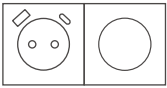

220V + USB A & C + Dimmer

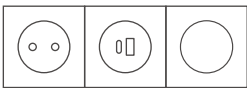

220V + USB A & C + Dimmer

Jung LS

Color: Anthracite Matt

Available options EU, FR

Jung LS

Color: Anthracite Matt

Available options UK

Gira

Color: Anthracite Matt

Available options DK

Other electrical outlet combinations available on request.



DIMENSIONS

Phonebooth

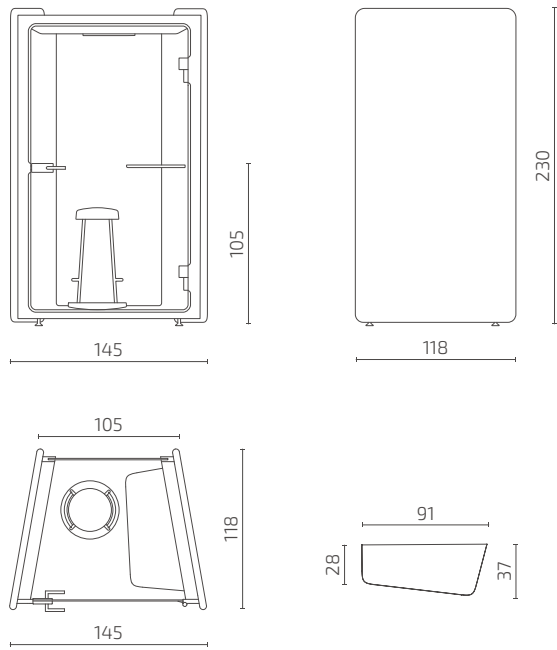

S122-BOOTH1

All dimensions provided in centimetres.

Bar height perch

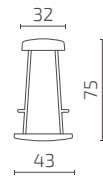

S122-BFL1

More Space

Booth's trapezoid shape is especially designed to feel spacious. It enables you to choose different positions. Its wide glass panels help you feel part of your wider surroundings, without being disturbed by them. And make the whole booth full of light. You can swing and turn on your chair, adapting your setup to whatever you need to work on.

