

# Office and Public Space

**intuit**  
BY SOFTREND

Furniture Collection 2026

## SEATING & WORKSATIONS



August  
pg 28



August Workbay  
pg 36



August Nook  
pg 42



August Wall  
pg 46



Ben  
pg 50



Don  
pg 54



Frankie  
pg 58



Harles  
pg 64



Hektor  
pg 70



Hubert & Hubert Mini  
pg 74



Ikoon  
pg 78



Intro  
pg 84



Kimi  
pg 86



Lilja  
pg 92



Loop, Duo & Twin  
pg 98



Meeter Modular  
pg 100



Meeter Gap  
pg 108



Meeter Round  
pg 114



Meeter Sofa & Armchair  
pg 118



Meeter Workbay  
pg 124



Node  
pg 128



Sans  
pg 136



Sofi  
pg 146



Takt  
pg 150



Wander  
pg 154

## PHONE POD



Intuit Booth  
pg 158



Aide  
pg 162



Alfred  
pg 166



Kuubik  
pg 168



Kuubik Side Table  
pg 172

## TABLES

## SCREENS, SPACE DIVIDERS & WALL PANELS



Grow  
pg 174



Hover  
pg 178



Note  
pg 184



Silent Note  
pg 182



Oaas  
pg 184



Sigmund  
pg 192



Sprout  
pg 194

# CONTENTS

## Intro

Environment matters	2
From Tradition to Innovation: the Intuit story	14
Intuit by Softrend and Sustainability	16
Sound-absorbing furniture	24

## Collection

### Seating & workstations

August	28
August Workbay	36
August Nook	42
August Wall	46
Ben	50
Don	54
Frankie	58
Harles	64
Hektor	70
Hubert & Hubert Mini	74
Ikoon	78
Intro	84
Kimi	86
Lilja	92
Loop, Duo & Twin	98
Meeter Modular	100
Meeter Gap	108
Meeter Round	114
Meeter Sofa & Armchair	118
Meeter Workbay	124
Node	128
Sans	136
Sofi	146
Takt	150
Wander	154

### Phone pod

Intuit Booth	158
--------------	-----

### Tables

Aide	162
Alfred	166
Kuubik	168
Kuubik Side Table	172

### Screens, space dividers & wall panels

Grow	174
Hover	178
Note	182
Silent Note	184
Oaas	186
Sigmund	192
Sprout	194

### Fabrics

Standard Fabric Collection	198
----------------------------	-----

# ENVIRONMENT MATTERS

At Intuit by Softrend, we understand that environments matter. Whether it's in the office or public spaces like educational facilities, libraries, cafeterias or public waiting areas, our furniture designs are crafted not only to fill spaces but to transform them. We believe in creating settings that nurture creativity, foster collaboration, and enhance productivity, making every space intuitive and lively. Each of Intuit's furniture pieces is designed with the goal of making spaces more adaptable, functional, and appealing. At Intuit by Softrend, we're committed to redefining how furniture interacts with spaces and its users.



GOOD FOOD - GOOD MOOD

# INTUITIVE FURNISHING FOR GETTING THINGS DONE



Our way of working has changed. It's the creative problem solving, agile collaboration, and the feeling of community we search for in the office. Intuit's designs have evolved to meet this shift.

We've taken the spirit of the breakout space and divided it into 4 distinctive work zones — each designed to meet a particular need to encourage creativity and connection.

Our 4 Zones use modular and multi-functional furniture solutions to make the most of every area of the office. Providing alternate spaces to choose where to work within the office drives a more effective workspace, a better work experience, and better individual performance. A win-win!

The world is moving fast — with Intuit, you make sure office space can keep up.



Welcome Zone



Social Zone



Collaboration Zone



Concentration Zone

## INTUITIVE OFFICE

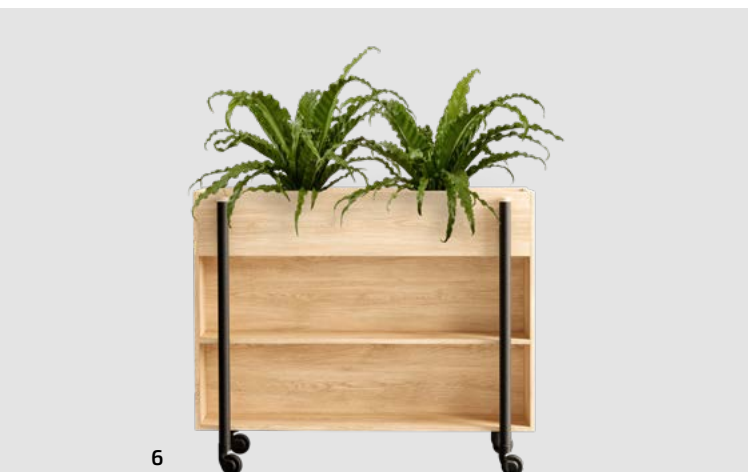

6



## INSPIRING LEARNING SPACES

At Intuit, we understand that effective learning environments extend beyond the traditional classroom setup of desks and chairs. Our vision is to create versatile spaces that cater to every aspect of the educational journey — from quiet study areas equipped with screens to dynamic group workspaces and comfortable lounges for relaxation and social interaction.

Our range of school furniture is designed to enrich learning experiences across all educational stages, from kindergartens to universities. We prioritize well-being for users of all ages and sizes, ensuring our furniture combines timeless design with functionality. Built to last, our pieces boast durable structures and are easy to maintain, making them a smart investment for long-lasting learning environments.

## TRANSFORMING THE WORKPLACE CAFÉ INTO A DYNAMIC HUB

At Intuit, we believe a contemporary workplace café does more than just serve food; it enriches the entire workplace experience. Far from being just a corporate eatery, it's a dynamic, multifunctional hub where employees can dine, meet, work, network, socialize, and reenergize. By activating underutilized spaces throughout the working day, it plays a crucial role in fostering employee productivity and well-being.





## ELEVATING THE LIBRARY SPACE

In the heart of every library, from the quiet corners of reading nooks to the collaborative buzz of communal spaces, the right seating can transform the experience. Intuit's range of library seating furniture is designed to meet every need— whether it's for individual study, group projects, or leisurely reading.

At Intuit, we believe in the power of timeless design, durability, and ease of maintenance to create inviting, long-lasting reading and learning environments. Discover seating solutions that cater to the diverse requirements of modern libraries, ensuring every visitor finds their perfect spot.

## ENHANCING TRANSIT SPACES INTO WELCOMING HUBS

The quality of waiting areas, whether in airports, hospital lobbies, conference centers, or large office buildings, significantly impacts user experience. Our approach to designing for these spaces centers on transforming mere transit areas into inviting hubs that offer comfort and function while waiting.

Inuit's public space collection is crafted to elevate waiting areas into more than just pass-through spaces; they become places where visitors can relax in comfort, catch up on work, or enjoy a peaceful moment away from the hustle and bustle. With Intuit's furniture, waiting becomes an experience in itself, characterized by style, comfort, and utility.



# FROM TRADITION TO INNOVATION: THE INTUIT STORY

## **Rooted in Craftsmanship**

Intuit by Softrend carries forward a legacy of over 25 years in the furniture industry, grounded in three generations of craftsmanship. Born from the established residential furniture brand Softrend, our journey began in a modest factory in Vääna, Estonia, where every sofa and bed is still handcrafted with precision. By managing every step of the production process, from meticulous quality control to extensive customization options, we uphold the highest standards. Our management system's adherence to ISO 9001:2015 and 14001:2015 reflects our commitment to consistent quality and environmental management.

## **Innovating for Tomorrow**

With a foundation deeply rooted in Softrend's extensive experience, Intuit by Softrend was launched in 2016 to revolutionize the public space furniture sector. We infuse a spirit of curiosity and innovation into Softrend's traditional expertise, creating functional, sustainable, and stylish furniture.

## **Sustainability at the Core**

At Intuit, sustainability isn't just a policy; it's a promise to our customers and the planet. We carefully select recyclable materials free from harmful chemicals, focusing on durable design to prolong the life of our products and lessen our environmental impact. Our design philosophy emphasizes product longevity, recyclability, and resource efficiency, ensuring that each piece not only serves its purpose but also contributes positively to the environment.

## **Quality and Value**

Our mission is to offer high-quality, durable designer furniture at fair prices, ensuring that while our prices are competitive, the quality and craftsmanship remain uncompromised. We believe that a quality product not only lasts longer but also provides greater value over time.

## **Vision for the Future**

Intuit is driven by a vision to enhance the daily lives of millions by creating the world's most inspiring and comfortable environments. Whether it's transforming offices into collaborative spaces or furnishing public areas like airports and hospitals, our goal is to make every environment a place where it's good to be. Our products are designed to nurture creativity, foster collaboration, and enhance productivity, ensuring that every space we touch is intuitive and vibrant.



THREE GENERATIONS  
OF FURNITURE-  
MAKING TRADITIONS  
SINCE 1997



# INTUIT BY SOFTREND AND SUSTAINABILITY

A growing number of informed consumers seek to make sustainable choices – but they can only do so if manufacturers make them possible. That's why Intuit by Softrend is steadfastly committed to sustainability, believing it's the only way to remain a responsible furniture manufacturer.

We recognize that the furniture industry has a significant environmental footprint. That's why we're taking action to reduce ours across the entire lifecycle of Softrend Group's products.

- 1** Reducing environmental impact by prioritizing chemical-free and recyclable materials.
- 2** Enhancing recyclability by considering the reuse of materials and components from the design phase.
- 3** Extending product lifespans and minimizing the need for replacement by designing durable, repairable products.
- 4** Lowering our ecological footprint through optimized storage, transport, resource efficiency, and weight reduction.



# PRIORITIES OF SOFTREND'S SUSTAINABILITY STRATEGY

Softrend's vision of sustainability relies on three principles, originating from **United Nations' Sustainable Development Goals**.

<p><b>Environment</b></p> <ul style="list-style-type: none"> <li>• Climate change</li> <li>• Circular economy</li> </ul>     	<p><b>Social responsibility</b></p> <ul style="list-style-type: none"> <li>• Consumer health and safety</li> <li>• Labor policies for value chain employees</li> <li>• Employee wellbeing</li> </ul>    	<p><b>Management</b></p> <ul style="list-style-type: none"> <li>• Transparency</li> <li>• Responsible management</li> </ul> 
--	--	---



# ALREADY PART OF OUR DAILY PRACTICES

## **Made to order**

We prevent excess stock by producing only what is needed.

## **Circular product design**

We design all new products for longevity. Easy to disassemble, they can be repaired, refreshed, and ultimately recycled.

## **Smart material choices**

We encourage our customers to choose durable materials by offering them as standard. More and more are also recyclable.

## **Minimizing waste**

Following ISO 1400:2015, we reduce waste, reuse what we can, and pass the rest to our partners.





A great example of circular design is the Hover soft leaning wall – its top layers slide easily together and apart, making it simple to replace worn components.



## WHERE ARE WE GOING?

### **More eco-labelled products**

Building on the success of the Meeter series, which already carries the EU Ecolabel, we plan to certify at least ten more products or product lines by the end of 2026.

### **Improved recycling**

We will increase the use of renewable and recycled materials in our products.

### **Circular economy products**

All future products will follow circular design principles, and we will update most existing designs accordingly.

### **More sustainable packaging**

We will prioritize recyclable transport packaging and reduce plastic use.

### **Enhanced governance & business ethics**

We ensure a safe, supporting work environment while maintaining ethical and transparent business practices.



MEETER – INTUIT'S  
FIRST EU ECOLABELLED  
PRODUCT SERIES



# EU ECOLABEL AND OUR PRODUCTS

The EU Ecolabel guarantees that a product is made in an environmentally and health-friendly way, has a long lifespan, and can be safely recycled. We are applying for Ecolabels for our products to help customers make more sustainable choices.

## Environment

The raw wood, cork, bamboo, or rattan used in Ecolabelled products comes from sustainably managed forests.

## Health

Ecolabelled furniture is produced without the use of hazardous chemicals, ensuring safety for everyone who comes into contact with it – both during production and use.

## Warranty

Ecolabelled products come with a long manufacturer's guarantee, reflecting their high quality and exceptional durability.

## Sustainability

Ecolabelled furniture is easy to dismantle, repair, and refresh – for example, by replacing the fabric and foam. This process further extends the product's lifespan.

## Ecolabelled fabrics

Intuit offers a range of around 1,500 fabrics, over half of them carry the Ecolabel. These 724 fabrics, each with distinctive looks and versatile characteristics, come from various manufacturers and are divided into multiple price categories.

## FSC certified wood

We already use 90% FSC-certified wood in the production of Intuit's products. This certification ensures that the wood is produced with equal regard for both the environment and economic viability.



Camira Oceanic fabric range is crafted from 100% recycled polyester and plastic sourced from marine debris.

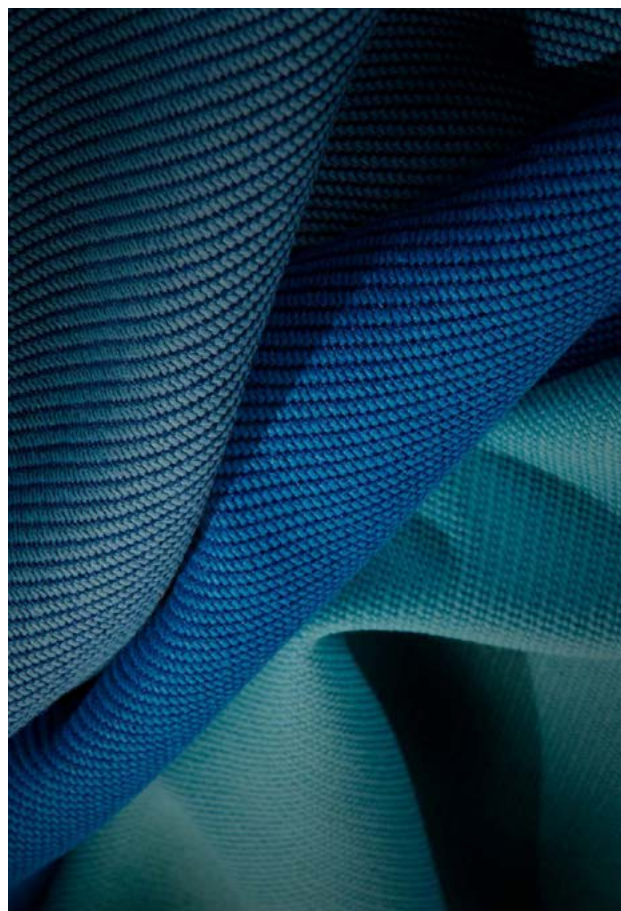

# SOUND-ABSORBING FURNITURE

Public space and open offices often have problems with resonance, meaning that sounds reverberate for too long. Sound waves cannot move freely in a closed room and bounce off the structure of the room. Some of the sound is absorbed by surfaces, while some reflects from them.

Monitoring sound absorption and achieving the recommended reverberation duration is one of the principal tasks in the acoustic design of rooms. Acoustic absorption means that sound does not reflect off a material after reaching it. That is also the principle of designing furniture with acoustic properties: furniture has to absorb the sound that would otherwise reflect back and contribute to unwelcome noise.

Creating a more pleasant environment requires us to dampen all kinds of different sounds, such as fans, people's footsteps, conversations and phone calls.

## **Acoustic August**

The entire August series is designed to improve office acoustics which makes it a perfect choice for an intuitive workplace. August product series gives you more absorption area in the room, e.g. better sound and less reverberance. A less reverberant room gives you better speech quality and less noise in the work environment.

The August products are rated at the highest Class A for sound attenuation. This means that they offer noise reduction equivalent to covering additional square meters of a room with 100% sound-absorbing material. The specific amount of square meters covered depends on the surface area of the chosen August model.





THE AUGUST PRODUCTS ARE RATED  
AT THE HIGHEST CLASS A  
FOR SOUND ATTENUATION

## Equivalent absorption area per object (m<sup>2</sup>Sab / object)

For example, the calculated sound absorption value for the August 2.5-Seat/H3 sofa model is 4.8m<sup>2</sup>/sab. This is comparable to completely covering an area of 4.8 m<sup>2</sup> with a material that absorbs 100% of sound. In practical terms, one August 2.5-Seat/H3 sofa provides the same noise reduction as about 12-13 sound absorber walls, each 50mm thick and covered with cloth or felt, measuring 600x600 mm.

**AKUKON** SOUND - VISION - VIBRATION  
 Calculated acoustic absorption values of August product range developed in cooperation with experts from Akukon

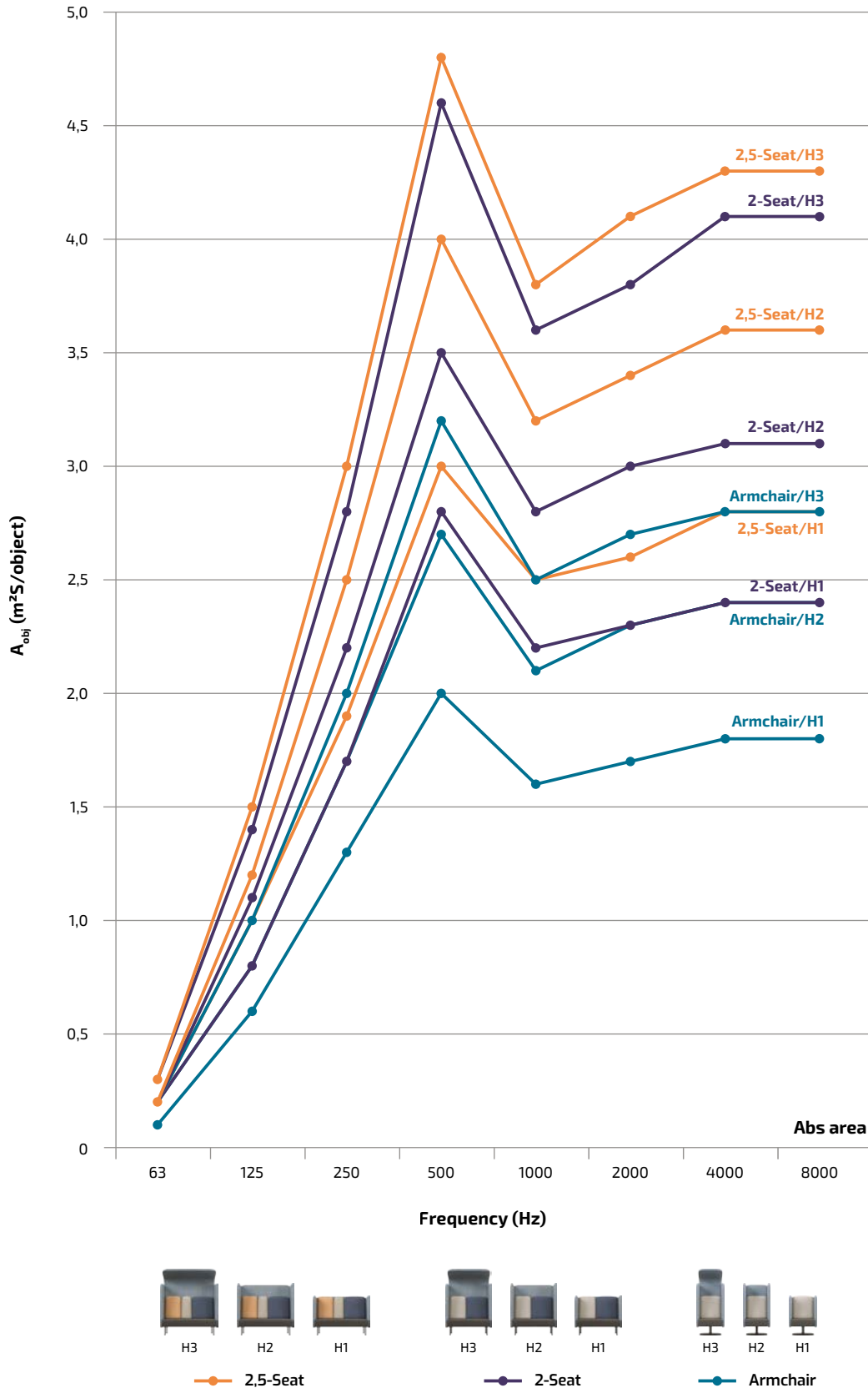

## Equivalent absorption area per object (m<sup>2</sup>Sab / object)

For example, the calculated sound absorption value for the August Workbay 2.5-Seat/H3 model is 10.7m<sup>2</sup>/sab. This is comparable to completely covering an area of 10.7 m<sup>2</sup> with a material that absorbs 100% of sound. In practical terms, one August Workbay 2.5-Seat/H3 provides the same noise reduction as about 29-30 sound absorber walls, each 50mm thick and covered with cloth or felt, measuring 600x600 mm.

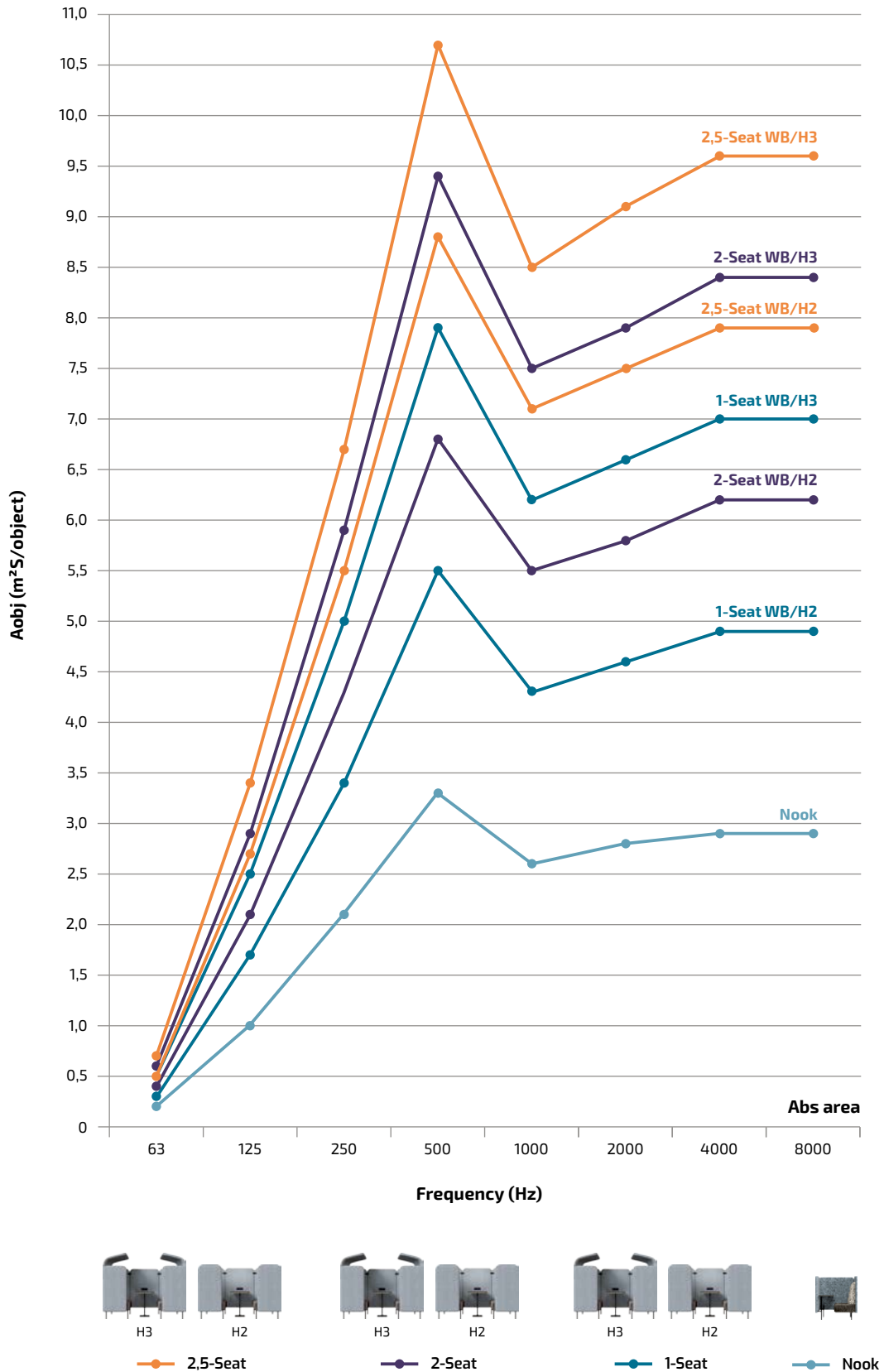

# August

## Sound-absorbing sofa and armchair

Design: Pent Talvet, Iseasi

The timeless and playful August series ranks among Intuit's TOP 3 popular products. We designed the August range to perfectly address the room acoustics issues which makes it a perfect choice for an intuitive workplace. Get away from the constant distractions, and quieten the noise when it's all too much.

With sound-absorbing walls, August gives you a private oasis within even the noisiest of surroundings, and the different height options make August versatile enough for conversations in your Social Zone, or focused individual work in your Concentration Zone.



Social Zone



Concentration Zone

Encourage focus and seclusion

Host private meetings

Divide your space organically

Cut down on background noise

## PRODUCT INFORMATION

### Versions

Available in 3 different heights and 3 different sizes

### Acoustics

Sound absorption class A

### Legs

Available with regular legs and 360° swivel base (only for armchair)

### Accessories

Tables to add functionality to the seating area

### Electrical outlet

Under the seating attached to the frame

### Warranty

5 years

### Sustainability

Embraces the principles of circular design

### Test & Certification

- L1 European Standard strength, durability and safety certificate
- Acoustic absorption test - Class A



## STANDARD MATERIALS

### Frame

Solid wood and plywood

### Seat & backrest

Durable HR foam; fire retardant HR foam on request; fixed seat and back cushions

### Legs

Solid oak / Powder-coated metal

### Tables

Matt high-pressure laminate, or mass-colored wood fibreboard top with matt powder-coated metal legs

### Fabric upholstery

The cover material is not removable  
Sides and rear wall of H3 models can exclusively be covered with felt fabric only

Choose any fabric from **Intuit Standard Fabric Collection**

### Additional information

As part of after-sales service we offer the change of cover fabric and all other components if needed

Vaisala office in Helsinki, Finland. Photo: Hannakaisa Pekkala



## LEGS



Solid oak legs, stained and varnished;  
anti-slip soles



Matt powder-coated metal legs;  
anti-slip soles



360° swivel base, powder-coated metal  
(only for armchair)

### **Solid oak**

Whitened



Natural



Wenge



Black

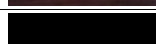

### **Powder-coated metal**

Jet Black RAL 9005



Other finishing options available on request.



Mustamäe State Gymnasium in Tallinn, Estonia. Photo: Märt Lillesiim





## TABLES



Aide table





### Aide tabletop

#### High-pressure laminate

Alpine White Egger W1100 PM	
Soft Black Egger U999 PM	
Stone Green Egger U665 PM	
Garnet Red Egger U399 PM	

### Aide table legs

#### Powder-coated metal

Signal White RAL 9003	
Jet Black RAL 9005	
Tarpaulin Grey RAL 7010	
Black Red RAL 3007	

Other finishing options available on request.

## ELECTRICAL OUTLET

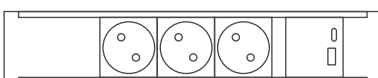

**3x 220V + USB A & C**

Other electrical outlet combinations available on request.



August side table

### August tabletop

#### High-pressure laminate, plywood edge

Black	
-------	---

#### Mass-colored wood fibreboard

Grey	
Black	

### August table frame

#### Powder-coated metal

Jet Black RAL 9005	
--------------------	---

### Bachmann Power Strip

Color: Black

Available options DK, EU, FR, UK



Armchair H1



Armchair H2



Armchair H3



Sofa 2-Seat / H1



Sofa 2-Seat / H2



Sofa 2-Seat / H3



Sofa 2,5-Seat / H1



Sofa 2,5-Seat / H2



Sofa 2,5-Seat / H3



Sofa 3-Seat / H1



Sofa 3-Seat / H2



Sofa 3-Seat / H3

## DIMENSIONS

### Armchair and sofa

Seat depth: 48 cm / Seat height: 45 cm

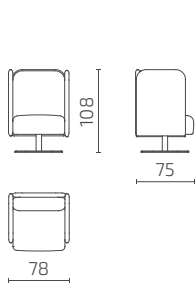

**S101-S1H1 (J-39)**

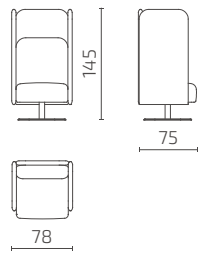

**S101-S1H2 (J-39)**

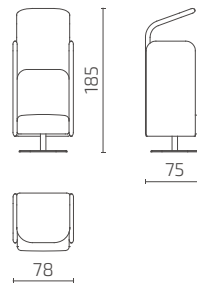

**S101-S1H3 (J-39)**

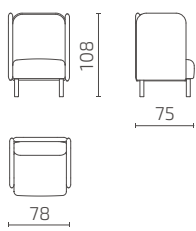

**S101-S1H1**

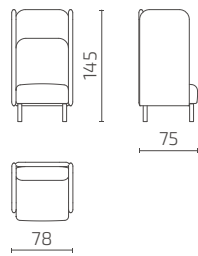

**S101-S1H2**

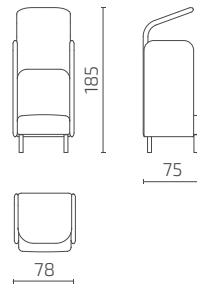

**S101-S1H3**

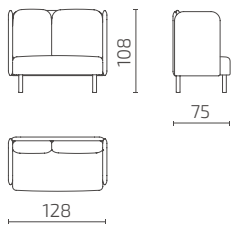

**S101-S2H1**

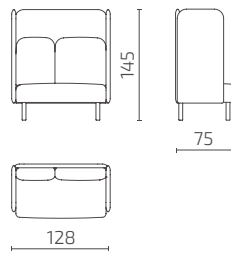

**S101-S2H2**

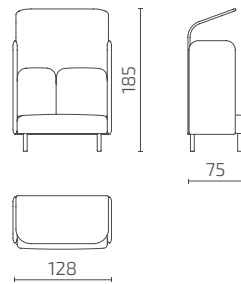

**S101-S2H3**

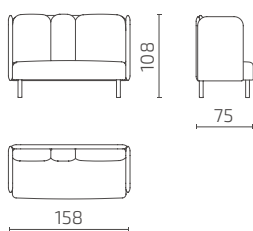

**S101-S25H1**

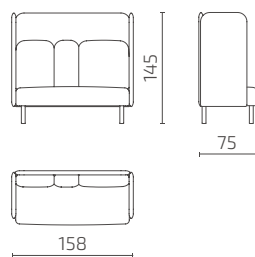

**S101-S25H2**

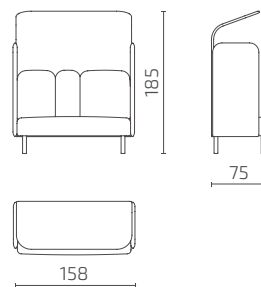

**S101-S25H3**

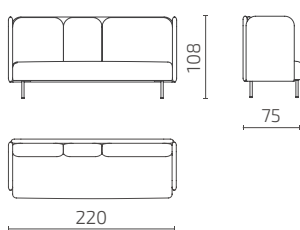

**S101-S3H1**

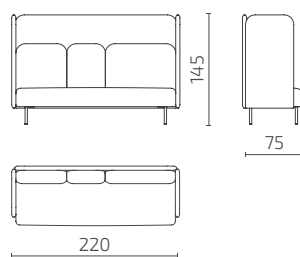

**S101-S3H2**

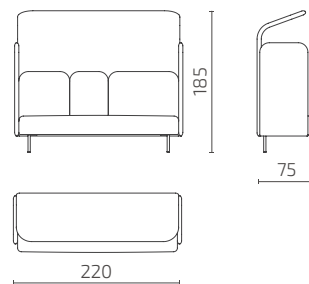

**S101-S3H3**

All dimensions provided in centimetres.

### Tables

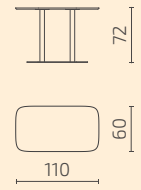

**S128-T1M**  
AIDE table

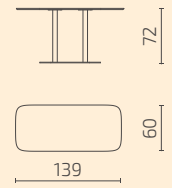

**S128-T3M**  
AIDE table

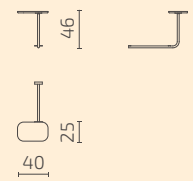

**S101-T2**  
AUGUST table





RebelRoam office in Tallinn, Estonia. Photo: Kristiina Vasar

# August Workbay

## Sound-absorbing workstation

Design: Pent Talvet, Iseasi

Looking for the perfect spot to have that important conversation? The August sofa set provides an easy solution for creating a workbay where you can go to get some privacy or have meetings. The August Workbay is an integral part of your Concentration Zone, providing an opportunity to step away from the noise, and find the focus you need.

The only thing it takes is to connect two August sofas or armchairs with a partition wall. Sound-absorbing qualities make it easy to carve out a space of peace and quiet within an open-plan office. Distraction-busting high sides with sound-absorbing qualities make it easy to carve out a space of peace and quiet within an open-plan surroundings.



Collaboration Zone



Concentration Zone

Divide your space organically

Cut down on background noise

Hold your own private meeting

Give the option of focus and seclusion

## PRODUCT INFORMATION

### Versions

Available in 2 different heights and 4 different sizes

### Acoustics

Sound absorption class A

### Accessories

Additional tables to add functionality to the seating area

### Electrical outlet

Integrated in the PC and TV wall

### Warranty

5 years

### Sustainability

Embraces the principles of circular design

### Test & Certification

- L1 European Standard strength, durability and safety certificate
- Acoustic absorption test - Class A



## STANDARD MATERIALS

### Frame

Solid wood and plywood

### Seat & backrest

Durable HR foam; fire retardant HR foam on request; fixed seat and back cushions

### Wall fastenings

Powder-coated metal

### Legs

Solid oak / Powder-coated metal

### Tables

Matt high-pressure laminate top with matt powder-coated metal legs

### Fabric upholstery

The cover material is not removable

Sides and rear wall of H3 models can exclusively be covered with felt fabric only

Choose any fabric from **Intuit Standard Fabric Collection**

### Additional information

As part of after-sales service we offer the change of cover fabric and all other components if needed



## LEGS



Solid oak legs, stained and varnished;  
anti-slip soles



Matt powder-coated metal legs;  
anti-slip soles

### **Solid oak**

Whitened



Natural



Wenge



Black



### **Powder-coated metal**

Jet Black RAL 9005



Other finishing options available on request.

## ELECTRICAL OUTLET

### **Integrated in the PC wall**

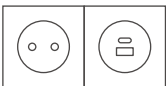

**220V + USB A & C**



**Berker Integro Flow**  
Color: Anthracite Matt

*Available options DK, EU, FR, UK*

### **Integrated in the TV wall**

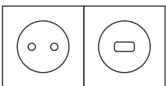

**220V + HDMI**



**Berker Integro Flow**  
Color: Anthracite Matt

*Available options DK, EU, FR, UK*

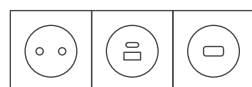

**220V + USB A & C + HDMI**

**Berker Integro Flow**  
Color: Anthracite Matt

*Available options DK, EU, FR, UK*

Other electrical outlet combinations available on request.





## TABLES



Aide cafeteria / work tables





### Aide tabletop

#### High-pressure laminate

Alpine White Egger W1100 PM	
Soft Black Egger U999 PM	
Stone Green Egger U665 PM	
Garnet Red Egger U399 PM	

### Aide table legs

#### Powder-coated metal

Signal White RAL 9003	
Jet Black RAL 9005	
Tarpaulin Grey RAL 7010	
Black Red RAL 3007	

Other finishing options available on request.

Payfit office in Paris, France





## DIMENSIONS

### Workbay

Seat depth: 48 cm / Seat height: 45 cm

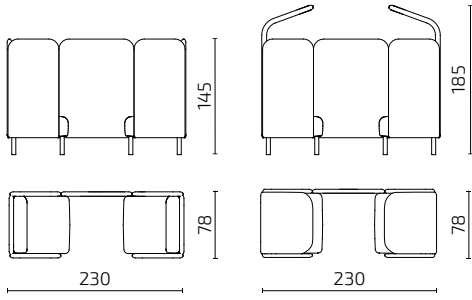

**S101-WS1H2**

**S101-WS1H3**

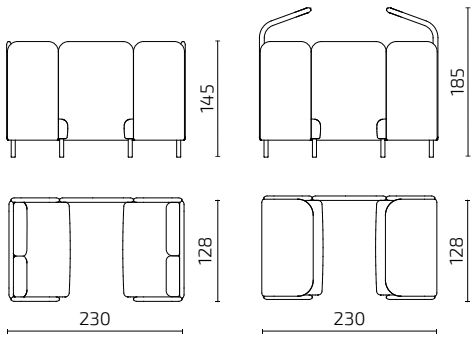

**S101-WS2H2**

**S101-WS2H3**

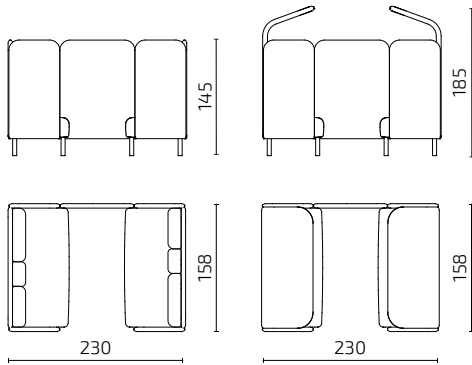

**S101-WS25H2**

**S101-WS25H3**

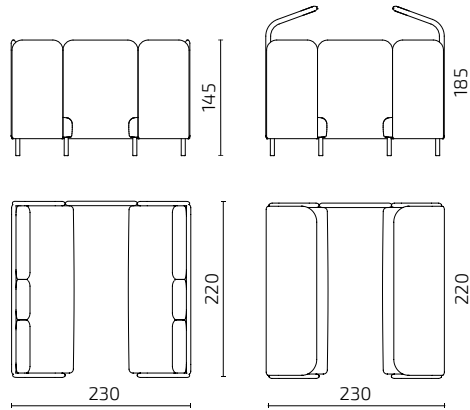

**S101-WS3H2**

**S101-WS3H3**

### Workbay wall

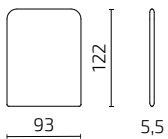

Regular wall



**S101-ELPC**

PC integrated  
electrical outlet

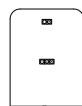

**S101-ELTV**

TV integrated  
electrical outlet

All dimensions provided in centimetres.

### Tables



**S128-T4M**  
AIDE table

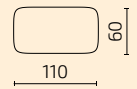
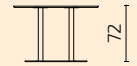

**S128-T1M**  
AIDE table

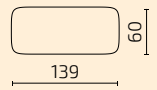
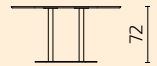

**S128-T3M**  
AIDE table

# August Nook

Available at  
**pCon**  
PLANNER

## Sound-absorbing workstation

Design: Pent Talvet, Iseasi

How do you provide a welcoming space for your hybrid workers? You need the compact 3-in-1 August Nook, with its built-in laptop size table, comfortable seat, and sound-absorbing screens.

Inviting you into a secluded spot that encourages focus and deep work, the Nook is somewhere you can slip into for an hour, or hang out in all day. Everything you need, all in one streamlined space.



Concentration Zone

Cut down on background noise

Divide your space with ease

Encourage focus and seclusion

## PRODUCT INFORMATION

### Versions

Left- or right-handed seat position

### Acoustics

Sound absorption class A

### Electrical outlet

Integrated in the table top

### Warranty

5 years

### Sustainability

Embraces the principles of circular design

### Test & Certification

- L1 European Standard strength, durability and safety certificate
- Acoustic absorption test - Class A



## STANDARD MATERIALS

### Frame

Solid wood and plywood

### Seat & backrest

Durable HR foam; fire retardant HR foam on request; fixed seat and back cushions

### Legs

Powder-coated metal

### Tables

Matt high-pressure laminate, or mass-colored wood fibreboard top with matt powder-coated metal frame

### Fabric upholstery

The cover material is not removable

Choose any fabric from **Intuit Standard Fabric Collection**

### Additional information

As part of after-sales service we offer the change of cover fabric and all other components if needed

Swedbank Eesti in Tallinn, Estonia. Photo: Helis Mahmastol



## FINISHING OPTIONS

### Legs

#### **Powder-coated metal**

Jet Black RAL 9005



### Tabletop

#### **High-pressure laminate, plywood edge**

Black



#### **Mass-colored wood fibreboard**

Grey



Black



### Table frame

#### **Powder-coated metal**

Jet Black RAL 9005



Other finishing options available on request.



## ELECTRICAL OUTLET



**220V**

#### **Powerdot Mini 50**

Color: Black Matt

*Available options CH, EU, FR*



**220V + USB A**

#### **Powerdot Compact 61**

Color: Black Matt

*Available options EU, FR, UK*

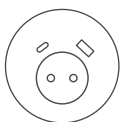

**220V + USB A & C**

#### **Powerdot 16**

Color: Black Matt

*Available options DK, EU, FR*

Other electrical outlet combinations available on request.

## DIMENSIONS

Seat depth: 48 cm / Seat height: 45 cm

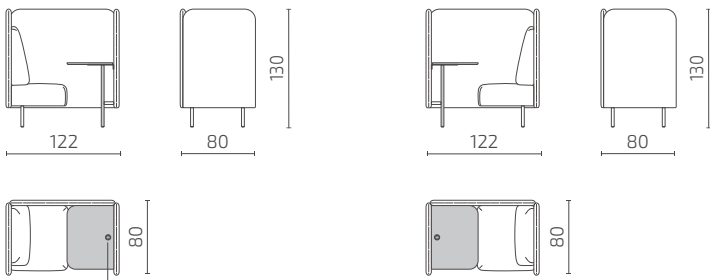

Integrated electrical outlet  
in the table top

**S101-NS1L**

**S101-NS1R**

All dimensions provided in centimetres.

Swedbank Eesti in Tallinn, Estonia. Photo: Helis Mahmastol



# August Wall

Available at  
**pCon**  
PLANNER

## Sound-absorbing wall panelling and bench

Design: Pent Talvet, Iseasi

Soft August Wall panels with a separate pouffe add a playful touch to the August range. Sound-absorbing panels help improve the acoustic properties of open rooms. Use the August Wall and bench combination to create areas of circulation, where colleagues can have encounters that brighten their day.



Welcome Zone



Social Zone

Make your visitors feel at home

Make connections with colleagues

Cut down on background noise

## PRODUCT INFORMATION

### Versions

Available in 2 different modules

### Warranty

5 years

### Sustainability

Embraces the principles of circular design

### Test & Certification

L1 European Standard strength, durability and safety certificate



## STANDARD MATERIALS

### Frame

Solid wood and plywood

### Seat & backrest

Durable HR foam; fire retardant HR foam on request

### Legs

Solid oak / Powder-coated metal

### Fabric upholstery

The cover material is not removable

Choose any fabric from **Intuit Standard Fabric Collection**

### Additional information

As part of after-sales service we offer the change of cover fabric and all other components if needed



## LEGS



Solid oak legs, stained and varnished;  
anti-slip soles



Matt powder-coated metal legs;  
anti-slip soles

### **Solid oak**

Whitened



Natural



Wenge

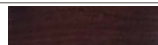

Black



### **Powder-coated metal**

Jet Black RAL 9005



Other finishing options available on request.

## PRODUCT CONSTRUCTION

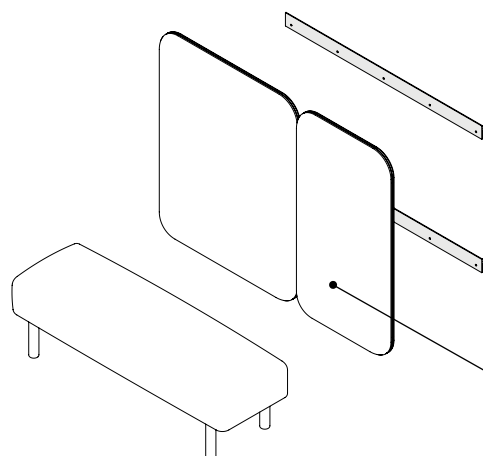
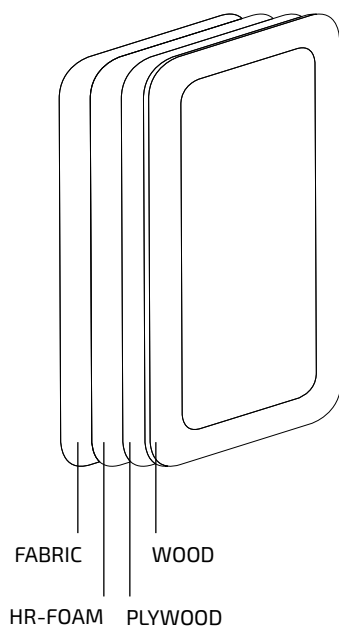

August Wall is a **separate panel**  
to be installed on the wall

## DIMENSIONS

### August bench

Seat depth: 48 cm

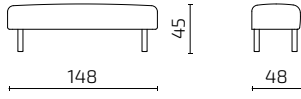

**S101-F25**

### Wall panel

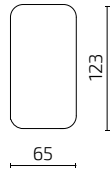

**S101-WS**

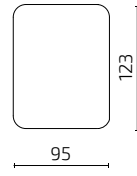

**S101-WM**

All dimensions provided in centimetres.



# Ben

## Soft office sofa

Design: Intuit design team

Sometimes the best business conversations happen away from the desk. Make sure your Social Zone sparks inspiration with the Ben Sofa. With versatile modules, you can create a piece of furniture that perfectly fits your space. And with Ben's springy softness your team will enjoy building connections over coffee.

Superior in design and comfort to the breakroom chairs you're used to, Ben shows your team how much you value their comfort and wellbeing. Put the finishing touches to your Social Zone with this inviting sofa.



Welcome Zone



Social Zone

Take a break

Make connections with colleagues

Make your visitors feel at home

Grab moments of rest

## PRODUCT INFORMATION

### Versions

Available in many different modules with and without armrests and 4 different pouffe sizes

### Accessories

Additional pillows, two sizes available

### Warranty

5 years

### Sustainability

Based on principles of the circular economy

### Certification



## STANDARD MATERIALS

### Frame

Solid wood and plywood, zigzag springs

### Seat and backrest

Durable HR foam; fire retardant HR foam on request

### Pillows

Feather or fibre filling

### Fabric upholstery

The cover fabric is not removable

Choose any fabric from **Intuit Standard Fabric Collection**

### Additional information

As part of after-sales service we offer the change of cover fabric and all other components if needed

Total Jobs office in Portsmouth, UK. Photo: Soren Kristensen



## SAMPLE COMBINATIONS

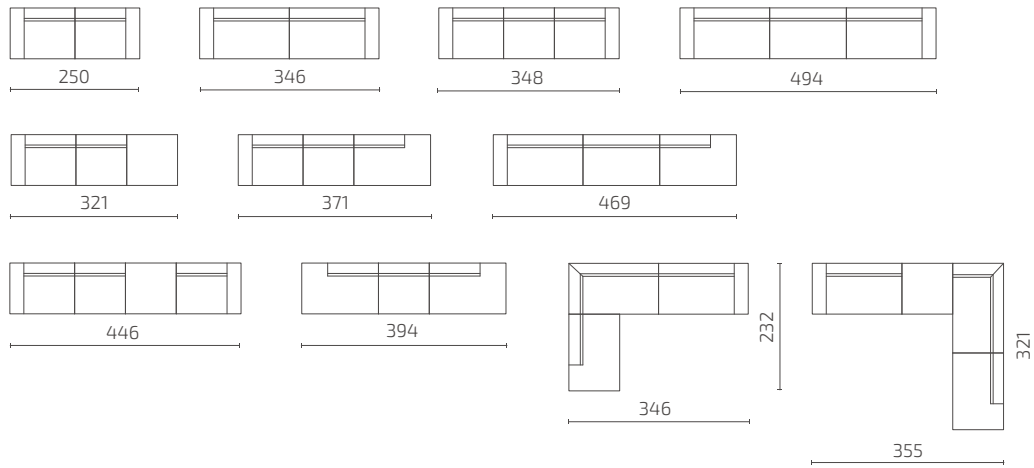

Separate module with armrest (left)



2-Seat with armrest (left) / Corner module (left) / Extended seat module (right)



2 x Footrest 4 / Extended seat module (right)



1.5-Seat with armrest (left) / 1.5-Seat with armrest (right)



Totaljobs office in Portsmouth, UK. Photo: Soren Kristensen

# DIMENSIONS

## Modules

Seat depth: 58 cm / Seat height: 37 cm

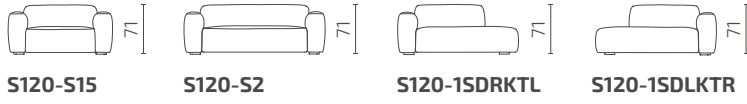
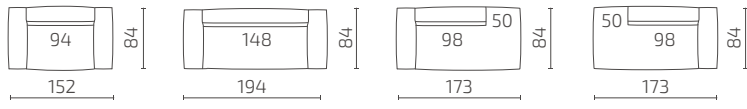

**S120-S15      S120-S2      S120-15DRKTL      S120-15DLKTR**

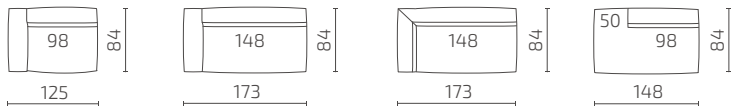

**S120-15CL      S120-2CL      S120-CL      S120-15DL**

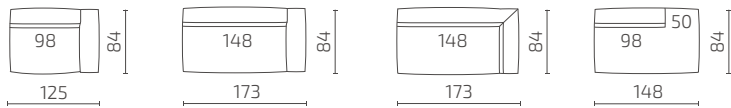

**S120-15CR      S120-2CR      S120-CR      S120-15DR**

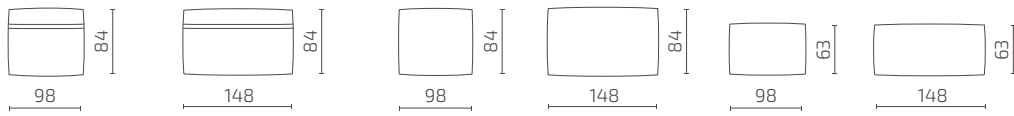

**S120-15      S120-2      S120-F1      S120-F2      S120-F3      S120-F4**

## Pillows

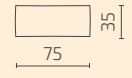

**S120-P1**

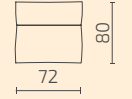

**S120-P2**

All dimensions provided in centimetres.

# Don

## Soft office sofa

Design: Intuit design team

While the lounge couch Ben serves as the focal point of the Social Zone, creating a comfortable space for colleagues to take a break from work, its larger counterpart, Don, elevates these breaks to a whole new level.

Don is as springy and as elegantly designed as Ben, but with a slightly deeper seating area, which adds a luxurious look and makes things more comfortable. Now everyone can get cosy and enjoy lying down, including four-legged members of the office.



Welcome Zone



Social Zone

Offer a spacious and comfortable seating area

Make guests feel at home

A great place to befriend colleagues

## PRODUCT INFORMATION

### Versions

Available in many different modules with and without armrests and 3 different pouffe sizes

### Accessories

Additional pillows, two sizes available

### Warranty

5 years

### Sustainability

Based on principles of the circular economy

### Certification



## STANDARD MATERIALS

### Frame

Solid wood and plywood, zigzag springs

### Seat and backrest

Durable HR foam; fire retardant HR foam on request

### Pillows

Feather or fibre filling

### Fabric upholstery

The cover fabric is not removable

Choose any fabric from **Intuit Standard Fabric Collection**

### Additional information

As part of after-sales service we offer the change of cover fabric and all other components if needed

Lithuanian Railway office in Vilnius, Lithuania. Photo: Lukas Jusas



## SAMPLE COMBINATIONS

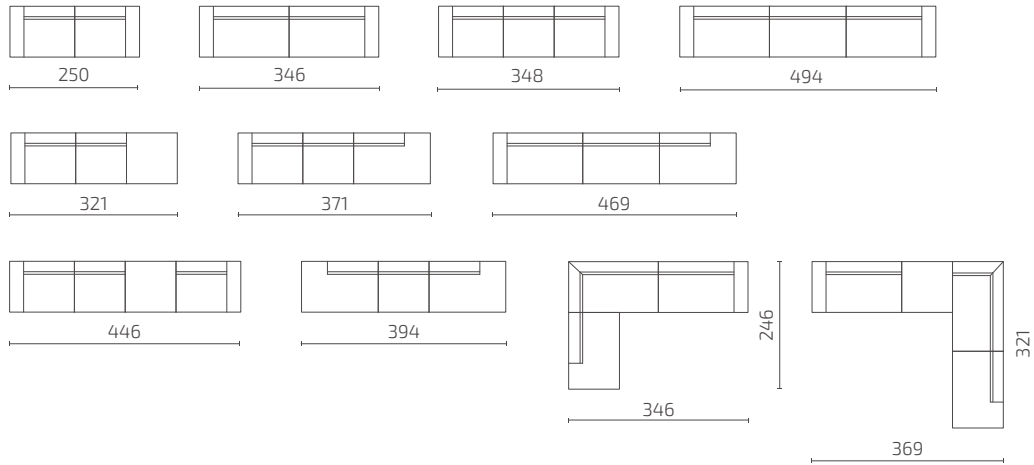

1.5-Seat with armrest (left) / 1.5-Seat



1.5-Seat with armrest (left) / 1.5-Seat / Footrest



1.5-Seat with armrest (left) / Extended seat module (right)



Separate module with armrest (left)



1.5-Seat with armrest (left) / 1.5-Seat with armrest (right)



2-Seat with armrest (left) / 2-Seat with armrest (right)



1.5-Seat with armrest (left) / 1.5-Seat / 1.5-Seat with armrest (right)



2-Seat / Corner module (left)



Extended seat module (left) / Corner module (left) / Extended seat module (right)

## DIMENSIONS

### Modules

Seat depth: 72 cm / Seat height: 37 cm

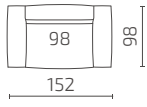

**S53-S15**

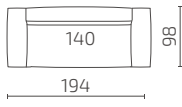

**S53-S2**

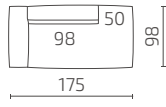

**S53-1SDRKTL**

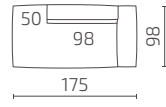

**S53-1SDLKTR**

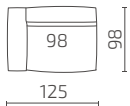
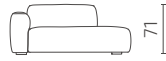
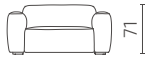

**S53-15CL**

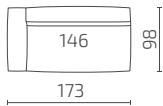

**S53-2CL**

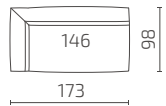

**S53-CL**

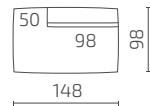

**S53-1SDL**

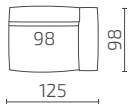
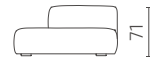
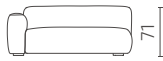

**S53-15CR**

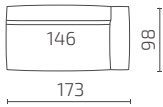

**S53-2CR**

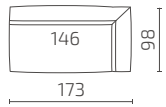

**S53-CR**

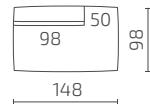

**S53-1SDR**

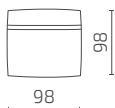
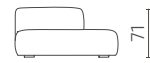
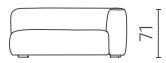

**S53-15**



**S53-2**

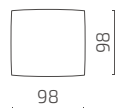

**S53-F1**

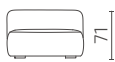

### Pillows

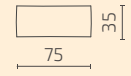

**S53-P1**

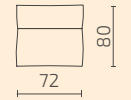

**S53-P2**

All dimensions provided in centimetres.

# Frankie

Available at  
**pCon**  
PLANNER

## Work sofa

Design: Argo Tamm

The slender and versatile Frankie embodies Intuit's agile ethos. With options of a sofa, armchair, and extended bench your imagination is the only limit. The set includes an attached table: a space for a computer, mug or magazine. Find your sweet spot with Frankie.



Collaboration Zone



Concentration Zone

Divide your space organically

Create focus and seclusion

Encourage rest

Host your own private meeting

## PRODUCT INFORMATION

### Versions

Available in many different dimensions

### Modularity

Modules can be connected together

### Accessories

Rotating attached side table to add functionality  
Extra pillow

### Electrical outlet

Under the seating attached to the frame

### Warranty

5 years

### Sustainability

Based on principles of the circular economy

### Test & Certification

L1 European Standard strength, durability and safety certificate



## STANDARD MATERIALS

### Frame

Metal, solid wood and plywood

### Seat & backrest

Durable HR foam; fire retardant HR foam on request

### Legs

Powder-coated metal; anti-slip soles

### Table

Matt high-pressure laminate, or mass-colored wood fibreboard top with matt powder-coated metal frame

### Pillow

Feather filling

### Fabric upholstery

The cover fabric is not removable

Choose any fabric from **Intuit Standard Fabric Collection**

### Additional information

As part of after-sales service we offer the change of cover fabric and all other components if needed

Pipedrive office in Tallinn, Estonia



## FINISHING OPTIONS

### Legs

#### *Powder-coated metal*

Jet Black RAL 9005



### Tabletop

#### *High-pressure laminate, plywood edge*

Black



#### *Mass-colored wood fibreboard*

Grey



Black



### Table frame

#### *Powder-coated metal*

Jet Black RAL 9005



Other finishing options available on request.



Frankie side table

## ELECTRICAL OUTLET

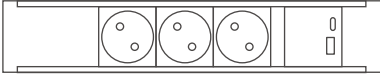

**3x 220V + USB A & C**

**Bachmann Power Strip**

Color: Black Matt

Available options *DK, EU, FR, UK*

Other electrical outlet combinations available on request.



## SAMPLE COMBINATIONS



1-Seat with 2 side wall



1-Seat with 3 side wall



2-Seat with double opposite 2 side walls



2-Seat with double 2 side walls



2-Seat with double 2/3 side walls



2-Seat with double 3 side walls





Net group office in Tallinn, Estonia. Photo: Tõnu Runnel

# DIMENSIONS

## Modules



## Table

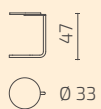

S107-T330

## Pillow

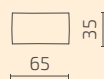

S107-DP

All dimensions provided in centimetres.

# Harles

## Soft office sofa

Design: Silver-Harles Haljandi

An office that feels like home creates a sense of warmth and belonging, where everyone feels welcomed and cared for. With its flowing form, Harles conveys this message in an effortless and chic way, with a touch of luxury.

The strength of the Harles sofa lies in its softness. Comfy seat cushions, filled with triple-layer foam, maintain their shape beautifully and make sitting a real pleasure. Designed with curves on all sides, Harles brings a sense of cosiness to any space, while its stylish high legs add an air of elegance. Opt for a seat module with a striking diagonal shape, and the character of Harles truly shines.



Welcome Zone



Social Zone



Collaboration Zone



Concentration Zone

Make waiting more comfortable

Feel homely and cosy

A nice place to chat

## PRODUCT INFORMATION

### Versions

Available in many different sizes

### Warranty

5 years

### Sustainability

Based on principles of the circular economy

### Certification



## STANDARD MATERIALS

### Frame

Solid wood and plywood, zigzag springs

### Seat and backrest

Durable HR foam; fire retardant HR foam on request

### Legs

Solid oak / Powder-coated metal

### Fabric upholstery

The cover fabric is removable

Choose any fabric from Intuit **Standard Fabric Collection**

### Additional information

As part of after-sales service we offer the change of cover fabric and all other components if needed



## LEGS



Solid oak legs, stained and varnished;  
anti-slip soles



Matt powder-coated metal legs;  
anti-slip soles

### **Solid oak**

Whitened



Natural



Wenge



Black



### **Powder-coated metal**

Jet Black RAL 9005



Other finishing options available on request.







Loveseat 1.5-Seat



3-Seat



3-Seat with corner module (right)



1.5-Seat with corner module (right)



1.5-Seat with small chaise longue (right)



1.5-Seat with extended chaise longue (right)



3-Seat with small chaise longue (right)



3-Seat with extended chaise longue (right)

## DIMENSIONS

Sofa height: 93 cm / Seat depth: 65 cm / Seat height: 43 cm

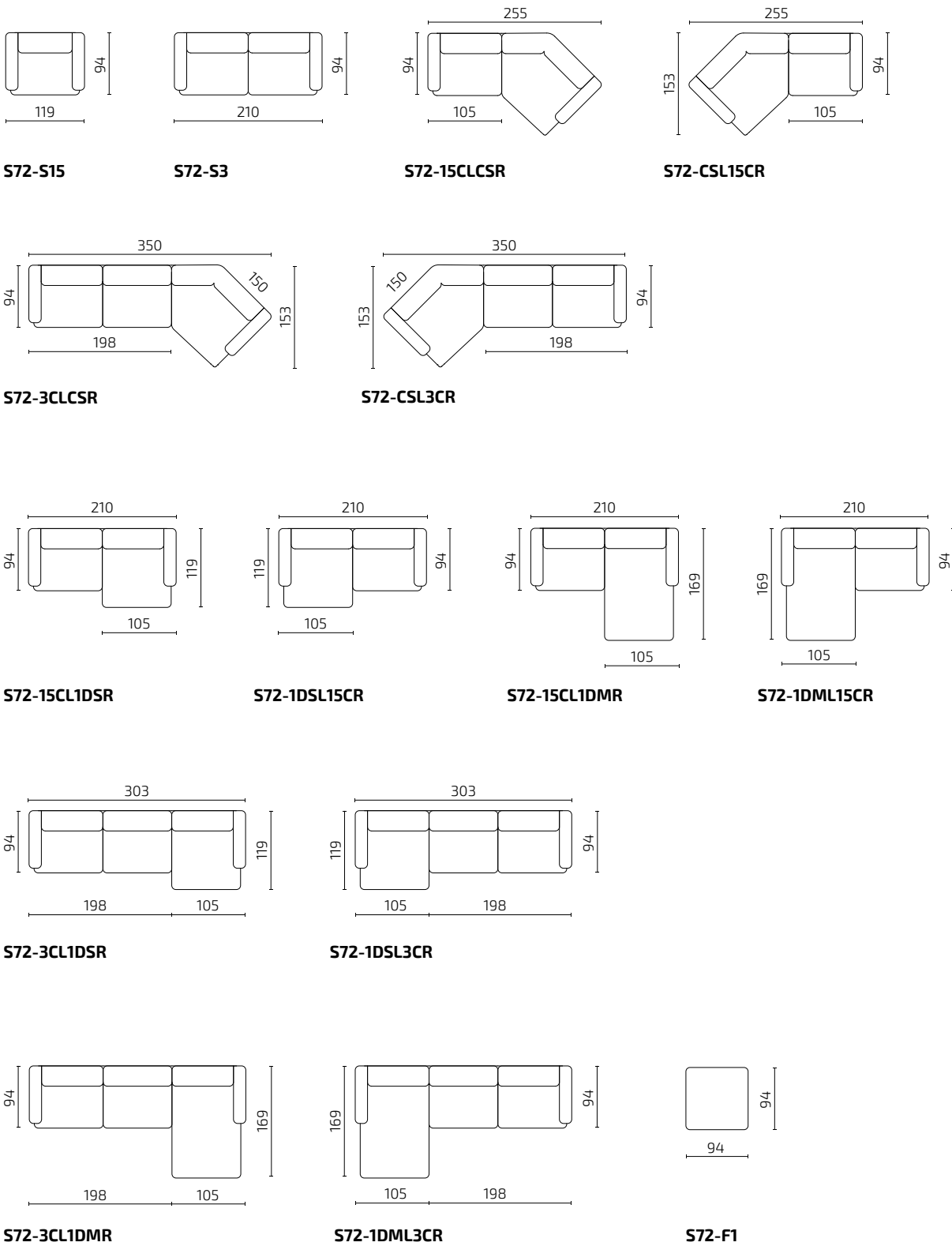

All dimensions provided in centimetres.

# Hektor

## Playful modular seating system

Design: Lauri Visnapuu

Designed for dynamic public and shared spaces, Hektor is a modular seating system built around soft, hexagonal forms that invite movement, interaction and flexible use. The playful geometry allows organic, non-linear configurations that work equally well as flowing seating landscapes or as individual standalone seats.

Available in three module heights — from low poufs to higher-backed elements — Hektor enables zoning, visual variation and optional privacy within open environments. Its generously upholstered, soft construction makes it comfortable for extended waiting, informal meetings or relaxed social moments.



Welcome Zone



Social Zone

Support comfort and interaction

Zone space with soft forms

Create organic seating layouts

## PRODUCT INFORMATION

### Versions

Available in 3 heights

### Modularity

Modules can be connected together

### Warranty

5 years

### Sustainability

Based on principles of the circular economy

### Certification



## STANDARD MATERIALS

### Frame

Plywood

### Seat and backrest

Durable HR foam; fire retardant HR foam on request

### Fabric upholstery

The cover fabric is removable

Choose any fabric from Intuit **Standard Fabric Collection**

### Additional information

As part of after-sales service we offer the change of cover fabric and all other components if needed





Ideal for airports, cultural venues, educational institutions and office lobbies, Hektor **brings structure and warmth** to high-traffic areas while offering architects freedom to shape space intuitively.

## DIMENSIONS

Seat depth: 51 cm

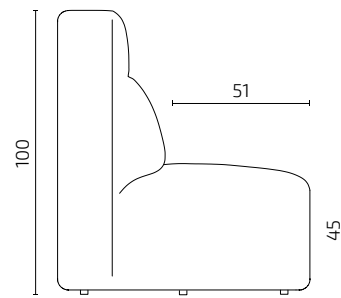
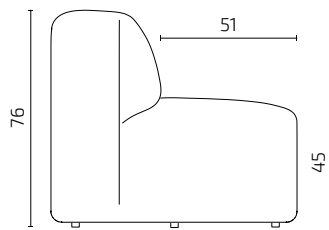
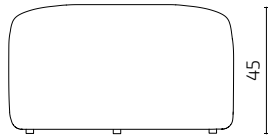
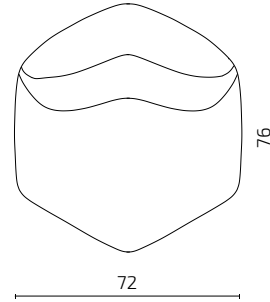
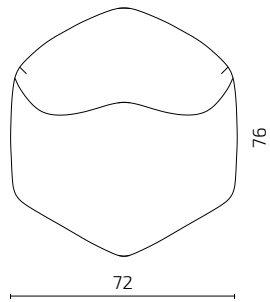
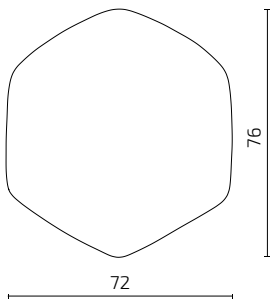

**S81-F1**

**S81-1H1**

**S81-1H2**

All dimensions provided in centimetres.



# Hubert & Hubert Mini

## High and low chair for meeting tables

Design: Iseasi

A chair that lets you brainstorm in style. The sleek frame and raised seat of the Hubert help to support ergonomic posture effortlessly, while the 360° swivel base lets you rotate and rock while ideating – great for productive and dynamic team meetings.

Simple to maneuver, these chairs help you create a welcoming and agile collaboration space at a moment's notice.



Collaboration Zone

Bring heads together at a moment's notice

Encourage active problem-solving

Make your office flexible

## PRODUCT INFORMATION

### Versions

Available in bar stool and regular seat height

### Rocking base

Available with a rocking base and 360° rotating & tilting base

### Warranty

5 years

### Sustainability

Based on principles of the circular economy

### Certification



## STANDARD MATERIALS

### Frame

Plywood

### Seat & backrest

Durable HR foam; fire retardant HR foam on request

### Legs

Rocking base: oak

360° rotating & tilting base: plastic POM, black

### Fabric upholstery

The cover fabric is removable

Choose any fabric from **Intuit Standard Fabric Collection**

### Additional information

As part of after-sales service we offer the change of cover fabric and all other components if needed

SK ID Solutions office in Tallinn, Estonia. Photo: Märt Lillesiim





Ev. Hochschule in Freiburg, Germany



The chic design also comes in miniature. **Hubert Mini** has all the benefits of ergonomic design, manoeuvrability, and style, whilst being just the right size for regular meeting tables.



## DIMENSIONS

### Rocking base

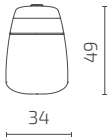
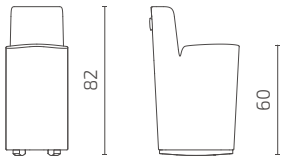

**S109-FL1**

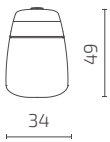
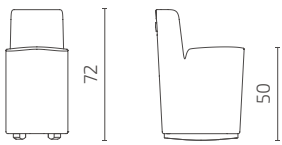

**S109-MFL1**

### 360° rotating & tilting base

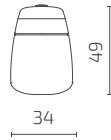
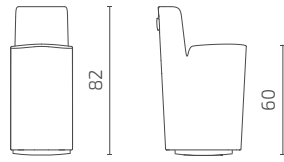

**S109-FL2**

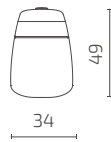
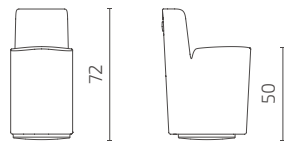

**S109-MFL2**

Seat depth: 36 cm

All dimensions provided in centimetres.



# Ikoon

## Compact privacy sofa system

Design: Argo Tamm

Designed for spaces where comfort, privacy and adaptability must coexist within a limited footprint, Ikoon is a compact sofa system that delivers focused seating without overwhelming the room. Its clean geometry and reduced dimensions make it easy to integrate into a wide range of interiors, while softly enclosing sides create a calm, personal seating experience.

Available in two heights, Ikoon supports different levels of interaction — from open, approachable seating to more enclosed use with enhanced visual and acoustic privacy. Integrated side tables provide a convenient surface for laptops or personal items, while optional power outlets — including an optional battery bank solution — enable power access without fixed connections, supporting mobile and laptop use and longer stays. With its compact form and optional castors, Ikoon can be easily repositioned as spaces and activities change.



Welcome Zone



Social Zone



Collaboration Zone



Concentration Zone

Reconfigure spaces with ease

Encourage focus and comfort

Create mobile privacy zones

## PRODUCT INFORMATION

### Versions

Available in 2 heights and 3 sizes

### Legs

Plastic legs / Rotating castors

### Accessories

Optional rotating side tables

### Electrical outlet

Optional integrated electrical outlet

### Cordless power bank

Optional integrated cordless power bank

### Warranty

5 years



## STANDARD MATERIALS

### Frame

Plywood

### Seat & backrest

Durable HR foam; fire retardant HR foam on request

### Side-tables

Matt high-pressure laminate with powder-coated metal frame

### Fabric upholstery

The cover material is not removable

Choose any fabric from **Intuit Standard Fabric Collection**

### Additional information

As part of after-sales service we offer the change of cover fabric and all other components if needed



## TABLES



Table T1



Table T2

### Tabletop

**High-pressure laminate**

Natural oak



### Table frame

**Powder-coated metal**

Jet Black RAL 9005



Other finishing options available on request.

## ELECTRICAL OUTLET



**Powerdot Compact 61**

Color: Black Matt

Available options EU, FR, UK

**220V + USB A**

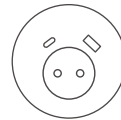

**Powerdot 16**

Color: Black Matt

Available options DK, EU, FR

**220V + USB A & C**

Other electrical outlet combinations available on request.

## CORDLESS POWER BANK

**QIKPAC**

Lithium-ion battery, 240 Wh

Color: Black Matt

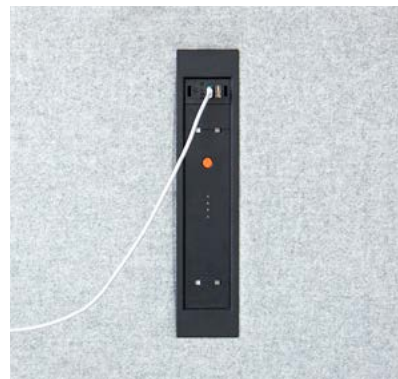



Ideal for offices, lobbies, lounges, larger meeting rooms and multi-use venues, Icoon is designed to support spaces that need to transform quickly. **Rather than dictating layout, it follows the rhythm of daily activity** — shifting effortlessly between waiting, informal meetings and focused individual use. Icoon performs equally well in transport hubs, educational settings and shared public interiors where adaptability and privacy are essential.



Armchair H1



Armchair H2



Sofa 2-Seat / H1



Sofa 2-Seat / H2



Sofa 3-Seat / H1



Sofa 3-Seat / H2

## DIMENSIONS

### Armchair and sofa

Seat depth: 54 cm / Seat height: 45 cm

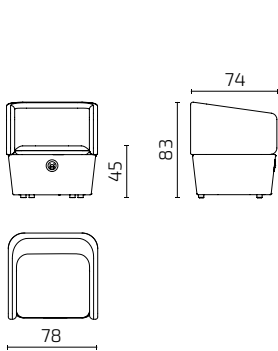

**S82-S1H1**

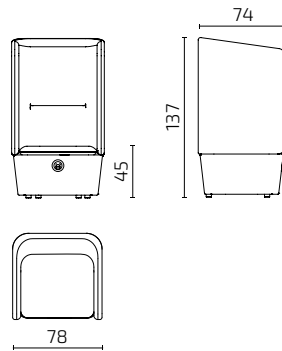

**S82-S1H2**

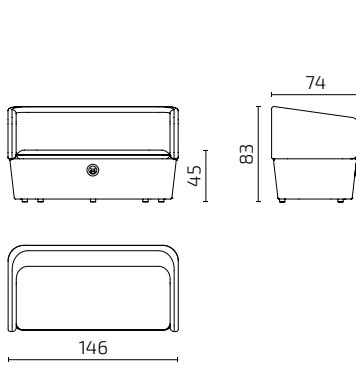

**S82-S2H1**

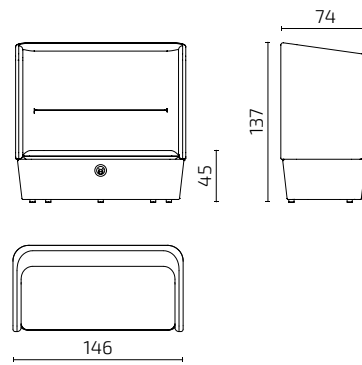

**S82-S2H2**

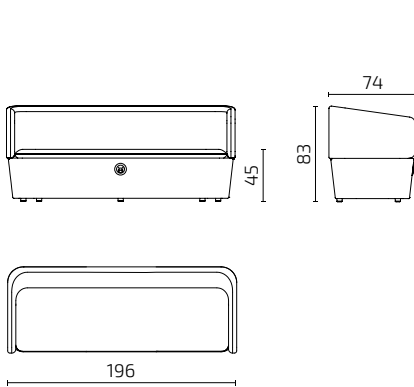

**S82-S3H1**

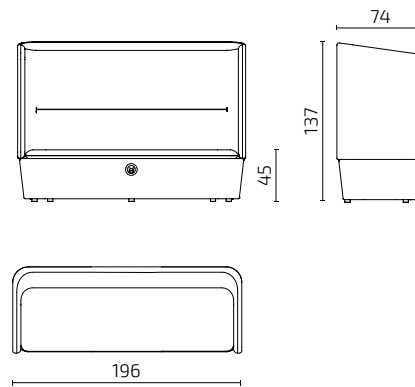

**S82-S3H2**

All dimensions provided in centimetres.

### Tables

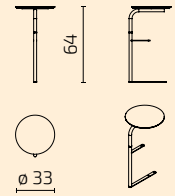

**S82-T1**

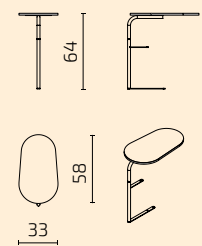

**S82-T2**

# Intro

## Lounge chair

Design: Argo Tamm

Not every office can cater for sprawling sofas and ping pong tables. But don't despair! If you're looking to create a flexible area for building community and encouraging relaxation, then we have what you need.

Compact, minimalist, oh so comfortable, Intro is easy to sink into with a cup of steaming coffee. And with its streamlined proportions you have an elegant solution to your space constraints.



Welcome Zone



Social Zone

Make your visitors feel welcome

Take a welcome break from your desk

Make connections with colleagues

## PRODUCT INFORMATION

### Leg

360° swivel base: metal leg and wood base

### Warranty

5 years

### Sustainability

Based on principles of the circular economy

### Certification



## STANDARD MATERIALS

### Frame

Metal

### Leg

Powder-coated metal leg and wood base

### Seat & backrest

High resiliency moulded PU foam

### Fabric upholstery

The cover fabric is not removable

Choose any fabric from **Intuit Standard Fabric Collection**

### Additional information

As part of after-sales service we offer the change of cover fabric and all other components if needed

## FINISHING OPTIONS

### Leg

#### Solid oak

Natural



Wenge



Black



#### Powder-coated metal

Jet Black RAL 9005



Stone Grey RAL 7030



Traffic White RAL 9016



Other finishing options available on request.

## DIMENSIONS

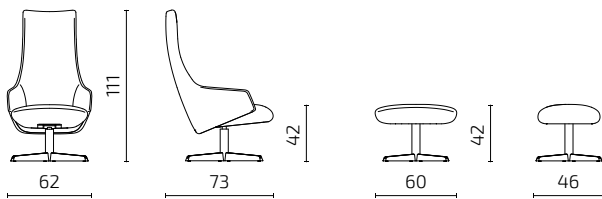

**S64-S1**

**S64-F1**

All dimensions provided in centimetres.



# Kimi

## Japandi-inspired, environmentally conscious sofa

Design: Argo Tamm

Inspired by Japandi style, Kimi brings balance, calm and conscious simplicity into the workplace. Its solid wood frame has a restrained, architectural presence, while adding warmth and natural character to the interior.

Thanks to its modular structure, Kimi can be configured into sofa compositions that suit a variety of spaces — from reception areas and lounges to quieter meeting and conversation zones. A practical movable armrest/table is available as an accessory: one side functions as a comfortable support to lean against, while the other provides a solid surface for a coffee cup, laptop or notebook. Decorative cushions can also be added to enhance back support and overall comfort.



Welcome Zone



Social Zone

Help create a balanced, low-stress environment

Offer comfortable seating for relaxed conversations

Support sustainable and responsible interior design

## PRODUCT INFORMATION

### Versions

Available in many different sizes

---

### Modularity

Modules can be connected together

---

### Accessories

Movable armrest / side table: double-sided, one side functions as a tabletop, the other as a padded armrest  
Decorative cushion: adds extra back comfort.

---

### Warranty

5 years

---

### Sustainability

Designed according to circular economy principles.  
All sofa components are easily replaceable, supporting long product life and responsible use

---

### Certification



## STANDARD MATERIALS

### Leg frame

Solid ash wood with long lamella profile  
Finishes: natural or oak stain (matte lacquer)

---

### Seat and back cushions

Back cushion: plywood frame with HS foam;  
Seat cushion: HR foam with bent plywood slats underneath

---

### Fabric upholstery

The covers are fully removable. 100% cotton base fabric  
Choose any fabric from Intuit **Standard Fabric Collection**

---

### Additional information

As part of our after-sales service, we offer replacement of upholstery and all other components when needed



## FINISHING OPTIONS

### Leg frame

#### **Solid ash**

Natural



Oak stain



Other finishing options available on request.



## One of Intuit's most sustainable sofa solutions



Kimi has been designed in line with **circular economy principles**. Instead of a traditional boxed construction, its frame is based on monomaterials, making the sofa fully recyclable. All upholstery covers are completely removable, allowing for easy maintenance and replacement — extending the product's lifespan and supporting long-term, responsible use.

## SAMPLE COMBINATIONS



1-Seat with armrest (left) / 2-Seat with extended seat (right)



1-Seat with small chaise longue / 2-Seat



2-Seat with armrest (left) / 1-Seat with small chaise longue



2-Seat / 2-Seat / 2-Seat with extended seat (right)



2-Seat with armrest (left) / 2-Seat / 2-Seat with extended seat (right)



Pouf



# DIMENSIONS

## Individual modules

Seat depth: 74 cm

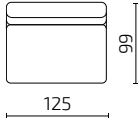
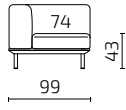
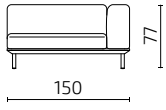

**S77-1**

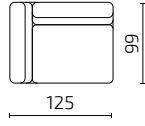

**S77-1CL**

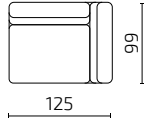

**S77-1CR**

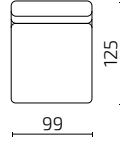

**S77-1D**

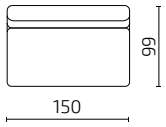

**S77-2**

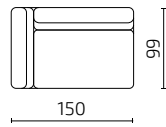

**S77-2CL**

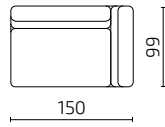

**S77-2CR**

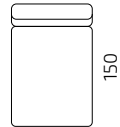

**S77-2D**

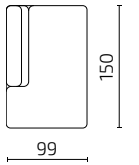

**S77-2SDL**

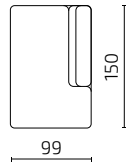

**S77-2SDR**

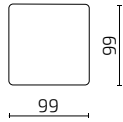

**S77-1F**

## Modules to combine

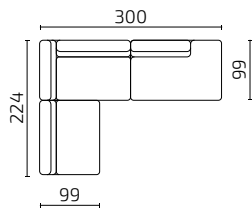

**S77-12CL2SDR**

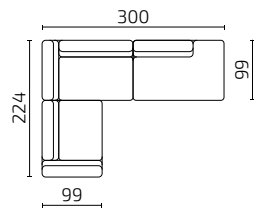

**S77-1CL2CL2SDR**

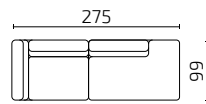

**S77-1CL2SDR**

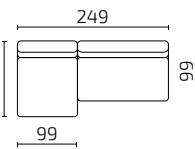

**S77-1D2**

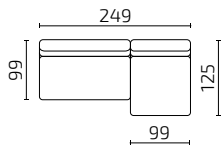

**S77-21D**

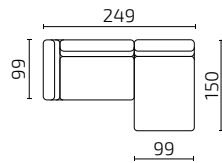

**S77-2CL2D**

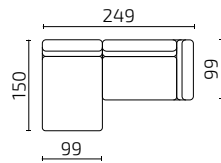

**S77-2D2CR**

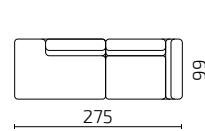

**S77-2SDL1CR**

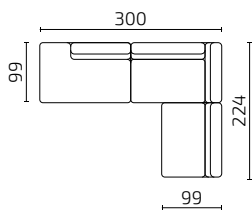

**S77-2SDL2CR1**

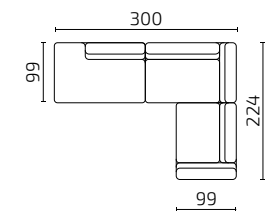

**S77-2SDL2CR1CR**

All dimensions provided in centimetres.

## Movable armrest/ side table

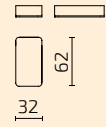

**S77-KT1**

## Decorative cushion

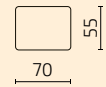

**S77-P1**

# Lilja

## Work sofa

Design: Samuli Naamanka

Transforming public spaces with Nordic elegance. Created in collaboration with Finnish designer Samuli Naamanka, Lilja is a tribute to the harmony and timelessness of Nordic design. Warm and friendly solid wood and elegant lines make up a pleasing piece of furniture that reflects the Nordic attitude to style and quality.

Lilja has flexibility at her heart, allowing you to tailor its setup to suit various spaces and personal tastes. Cherry-pick the armrest combinations. Optional backseat and armrest pillows enhance the comfort, inviting you to sink in and experience its welcoming embrace. Whether it's your office or any public area, Lilja promises to transform ordinary spaces into cozy, inviting environments. Much you value their comfort and wellbeing. Put the finishing touches to your Social Zone with this inviting sofa.



Welcome Zone



Social Zone

Foster connections among colleagues

Welcome your visitors with a touch of home

Offer a restorative retreat from the daily grind

## PRODUCT INFORMATION

### Versions

Many different modules with and without armrests

### Modularity

Modules can be connected together

### Accessories

Additional backseat and armrest pillows

### Warranty

5 years

### Sustainability

Based on principles of the circular economy

### Certification



## STANDARD MATERIALS

### Frame

Solid wood and plywood

### Seat and backrest

Durable HR foam; fire retardant HR foam on request

### Leg frames

Solid oak / Powder-coated metal

### Pillows

Feather or fibre filling

### Fabric upholstery

The cover fabric is not removable

Choose any fabric from **Intuit Standard Fabric Collection**

### Additional information

As part of after-sales service we offer the change of cover fabric and all other components if needed

Tartu University Clinic, Estonia. Photo: Märt Lillesiim



## FINISHING OPTIONS

### Leg frame

#### *Solid oak*

Natural

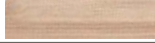

#### *Powder-coated metal*

Jet Black RAL 9005



Other finishing options available on request.



## SAMPLE COMBINATIONS

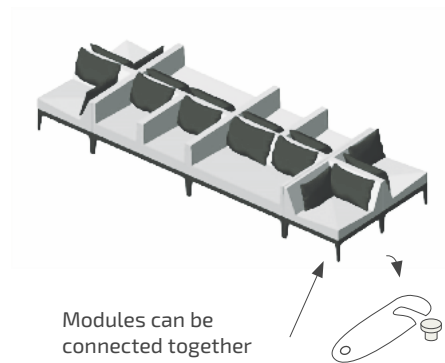
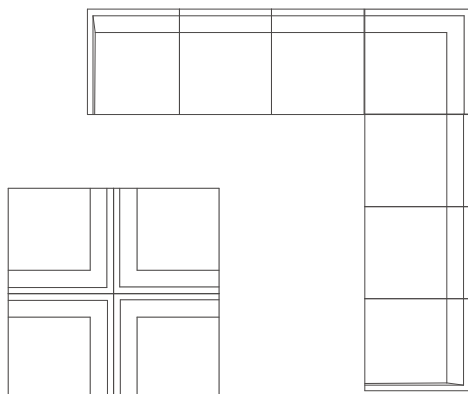
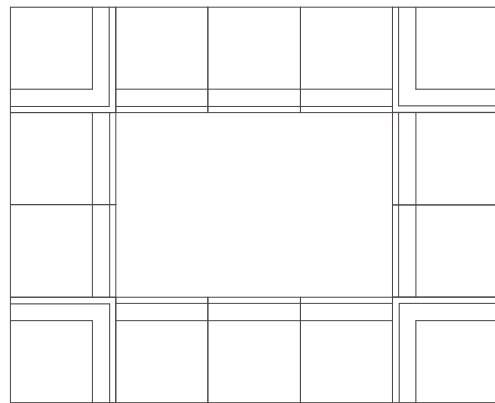
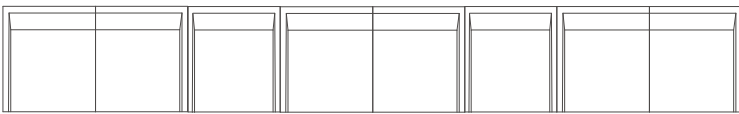
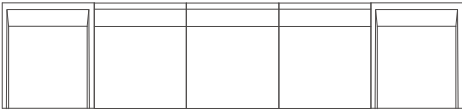
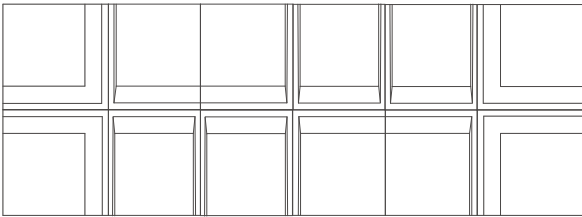



Tartu University Clinic, Estonia. Photo: Märt Lillesim



Tartu University Clinic, Estonia. Photo: Märt Lillesiim

## DIMENSIONS

### Modules

Seat depth: 61 cm, with extra pillow 48 cm

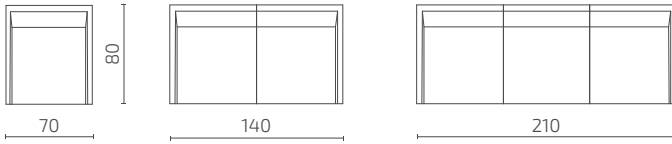
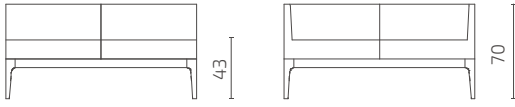

**S102-S1**

**S102-1CL1CR**

**S102-1CL11CR**

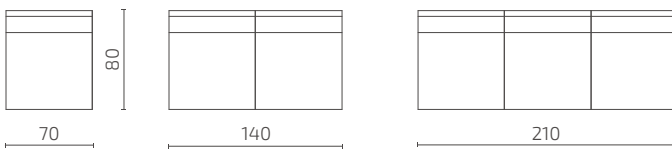

**S102-1**

**S102-11**

**S102-111**

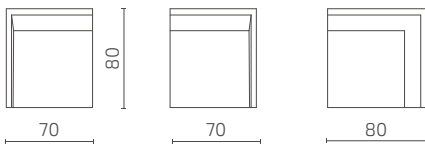

**S102-1CL**

**S102-1CR**

**S102-C**

### Oak leg frames

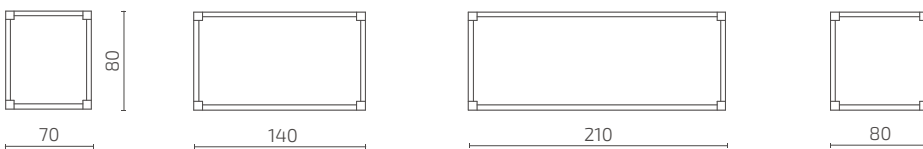

**A0803-0039**

**A0803-0040**

**A0803-0041**

**A0803-0042**

### Metal leg frames

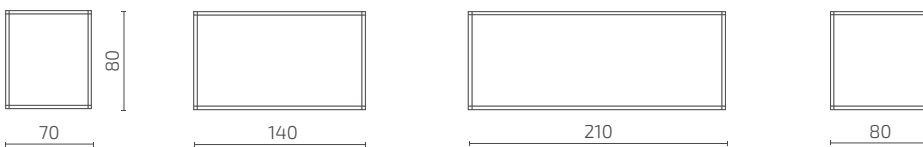

**A0803-0050**

**A0803-0051**

**A0803-0052**

**A0803-0053**

All dimensions provided in centimetres.

### Pillows

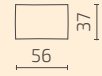

**S102-P**  
Back pillow

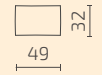

**S102-KTP**  
Armrest pillow

# Loop, Duo & Twin

## Poufs

Design: Lauri Visnapuu

We think you should be able to gather wherever inspiration strikes. Which is why we've designed our trio of playful poufs to be the ultimate in flexible seating.

Grab them by their tabs and pull them over to your colleague's desk. So that you can carry on forming your new idea, without getting a crick in your neck.



Welcome Zone



Social Zone



Collaboration Zone

Make your seating super flexible

Bring some playful energy

Gather wherever you need to

## PRODUCT INFORMATION

### Versions

Available in 3 different shapes

### Warranty

5 years

### Sustainability

Based on principles of the circular economy

### Certification



## STANDARD MATERIALS

### Frame

Solid wood and plywood

### Seat

Durable HR foam; fire retardant HR foam on request

### Fabric upholstery

The cover fabric is not removable

Choose any fabric from **Intuit Standard Fabric Collection**

### Additional information

As part of after-sales service we offer the change of cover fabric and all other components if needed

## DIMENSIONS

### Loop

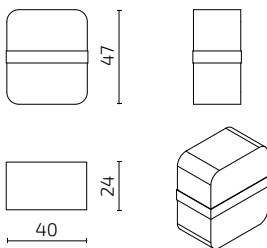

**S116-F47**

### Duo

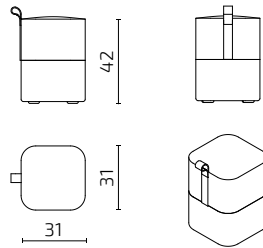

**S117-F31**

### Twin

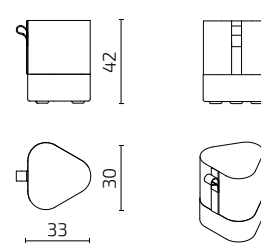

**S118-F33**

All dimensions provided in centimetres.



# Meeter Modular

## Sofa modules

Design: Argo Tamm

Don't let your chairs distract from your chat. You can use the effortless design of the Meeter sofa modules wherever you want to bring people together. Perfect for those office reception areas and work cafes, Meeter has also found a happy home in the dining halls of catering establishments.

Renowned for its exceptional adaptability in both height and length, the Meeter sofa seamlessly integrates into any milieu. These compact sofas are engineered for endurance, effortlessly withstanding heavy usage and frequent cleaning.



Welcome Zone



Social Zone

Create compact waiting spots

Make even your smaller dining areas comfy

Optimize space with flexible seating

## PRODUCT INFORMATION

### Versions

Available in 3 different heights and in 7 standard lengths

### Modularity

Modules can be connected together

### Legs

Available with regular legs and plinth

### Accessories

Attached side table to add functionality

Custom-made planter boxes to offer an organic touch of privacy

### Electrical outlet

Integrated electrical outlet

### Warranty

10 years

### Sustainability

Based on principles of the circular economy

### Test & Certification

- L2 European Standard strength, durability and safety certificate
- EU Ecolabel Certified



EU Ecolabel: EE/049/001



100%  
From well-  
managed forests  
FSC® C170945

## STANDARD MATERIALS

### Frame

Solid wood and plywood

### Seat & backrest

Durable HR foam; fire retardant HR foam on request

### Legs

Solid oak / Powder-coated metal

Plinth: Veneer / Melamine / High-pressure laminate

### Table

Mass colored wood fibreboard / high-pressure laminate top with plywood edge; powder-coated metal frame

### Planter box

Veneer / Melamine / High-pressure laminate

### Fabric upholstery

The cover material is not removable

Choose any fabric from **Intuit Standard Fabric Collection**

### Additional information

As part of after-sales service we offer the change of cover fabric and all other components if needed

Swedbank Eesti in Tallinn, Estonia. Photo: Helis Mahmastol



## LEGS



Solid oak legs, stained and varnished; anti-slip soles







Powder-coated metal; anti-slip soles. Available in U-shape and straight legs



Plinth  
Additional cost will apply



### **Solid oak**

Whitened	
Natural	
Wenge	
Black	

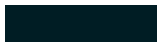
### **Powder-coated metal**

Jet Black RAL 9005	
--------------------	---

### **Plinth**

Natural oak veneer	
Black melamine	
Black high-pressure laminate	

Other finishing options available on request.

## TABLE

### **Tabletop**

#### **High-pressure laminate, plywood edge**

Black	
-------	---

#### **Mass-colored wood fibreboard**

Grey	
Black	

### **Table frame**

#### **Powder-coated metal**

Jet Black RAL 9005	
--------------------	---



Meeter side table

Other finishing options available on request.

## PLANTER BOX

Natural oak veneer



Black melamine



Black high-pressure laminate



Other finishing options available on request.

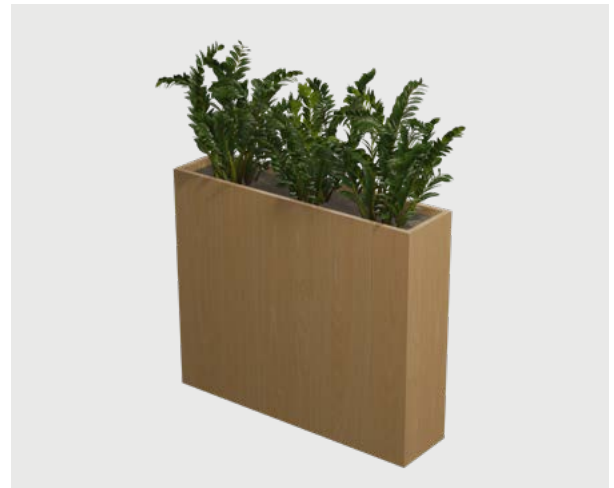

## ELECTRICAL OUTLET

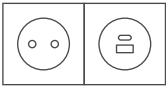

**220V + USB A & C**

Other electrical outlet combinations available on request.

**Berker Integro Flow**

Color: Anthracite Matt

Available options DK, EU, FR, UK

Totaljobs office in Portsmouth, UK. Photo: Soren Kristensen



# SAMPLE MODULES



Length 100 cm / H1



Length 100 cm / H2



Length 100 cm / H3



Left corner / Length 100 cm / H1



Left corner / Length 100 cm / H2



Left corner / Length 100 cm / H3



Right corner / Length 100 cm / H1



Right corner / Length 100 cm / H2



Right corner / Length 100 cm / H3

# DIMENSIONS

## Modules

Seat depth: 45 cm / Seat height: 46 cm  
 Standard lengths 62 / 80 / 100 / 120 / 150 / 180 / 200  
 Custom lengths available up to 230 cm

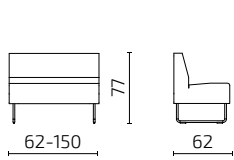

### S108-1H162

- S108-1H180
- S108-1H1100
- S108-1H1120
- S108-1H1150
- S108-1H1180
- S108-1H1200

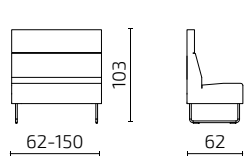

### S108-1H262

- S108-1H280
- S108-1H2100
- S108-1H2120
- S108-1H2150
- S108-1H2180
- S108-1H2200

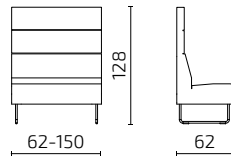

### S108-1H362

- S108-1H380
- S108-1H3100
- S108-1H3120
- S108-1H3150
- S108-1H3180
- S108-1H3200

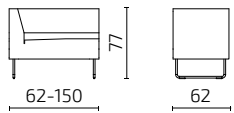

### S108-1CLH162

- S108-1CLH180
- S108-1CLH1100
- S108-1CLH1120
- S108-1CLH1150
- S108-1CLH1180
- S108-1CLH1200

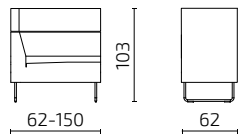

### S108-1CLH262

- S108-1CLH280
- S108-1CLH2100
- S108-1CLH2120
- S108-1CLH2150
- S108-1CLH1180
- S108-1CLH1200

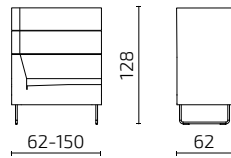

### S108-1CLH362

- S108-1CLH380
- S108-1CLH3100
- S108-1CLH3120
- S108-1CLH3150
- S108-1CLH3180
- S108-1CLH3200

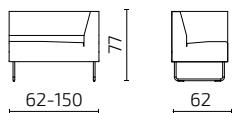

### S108-1CRH162

- S108-1CRH180
- S108-1CRH1100
- S108-1CRH1120
- S108-1CRH1150
- S108-1CRH1180
- S108-1CRH1200

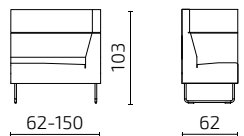

### S108-1CRH262

- S108-1CRH280
- S108-1CRH2100
- S108-1CRH2120
- S108-1CRH2150
- S108-1CRH2180
- S108-1CRH2200

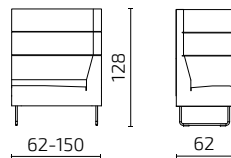

### S108-1CRH362

- S108-1CRH380
- S108-1CRH3100
- S108-1CRH3120
- S108-1CRH3150
- S108-1CRH3180
- S108-1CRH3200

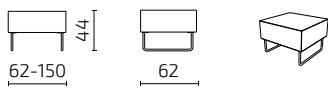

### S108-F62

- S108-F80
- S108-F100
- S108-F120
- S108-F150
- S108-F180
- S108-F200

## Table



### S108-T1

## Planter boxes

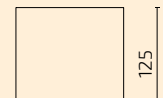
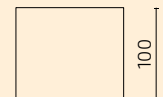
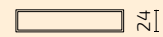
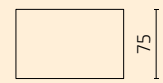

Length tailored to the full length of modular sofa

## Inner dimensions

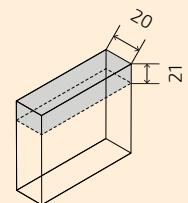

All dimensions provided in centimetres.



Swedbank Eesti in Tallinn, Estonia. Photo: Helis Mahmastol

**Shallow seating** makes the Meeter perfect for tighter places



Finnish Transport Infrastructure Agency in Helsinki, Finland. Photo: Hannakaisa Pekkala

# Meeter Gap

## Maintenance-smart modular sofa modules

Design: Argo Tamm

Developed as an evolution of Intuit's best-selling Meeter modular sofa series, Meeter Gap is designed to solve one of the most common yet costly challenges in high-traffic environments: difficult cleaning and ongoing maintenance.

Its key innovation lies in the structural gap between the seat cushion and backrest — a purposeful design detail that allows crumbs, debris and dirt to fall directly to the floor instead of accumulating inside the furniture. This significantly simplifies cleaning, speeds up maintenance routines and helps reduce long-term upkeep costs in spaces where furniture is used intensively every day.

Especially suited for dining areas, educational settings, waiting zones and other demanding public interiors, Meeter Gap combines the proven flexibility and modularity of the Meeter family with a practical operational advantage. The result is a seating solution that not only supports layout adaptability and user comfort, but also improves day-to-day efficiency for operators and facility managers.



Welcome Zone



Social Zone

Create more efficient, lower-maintenance spaces

Simplify daily cleaning and upkeep

Design smarter environments

## PRODUCT INFORMATION

### Versions

Available in one height and in four standard lengths for the straight modules and three standard lengths for the sofa versions. Straight and inward and outward-facing curved modules.

### Modularity

Modules can be connected together

### Accessories

Attached side table to add functionality

### Electrical outlet

Integrated electrical outlet

### Warranty

5 years

### Sustainability

Based on principles of the circular economy

### Certification



## STANDARD MATERIALS

### Frame

Plywood and HDF

### Seat & backrest

Durable HR foam; fire retardant HR foam on request

### Legs

Powder-coated metal; plastic soles

### Table

Mass colored wood fibreboard / high-pressure laminate top with plywood edge; powder-coated metal frame

### Fabric upholstery

The cover material is not removable

Choose any fabric from **Intuit Standard Fabric Collection**

### Additional information

As part of after-sales service we offer the change of cover fabric and all other components if needed



## LEGS

### **Powder-coated metal**

Jet Black RAL 9005



Other finishing options available on request.



## TABLE

### **Tabletop**

#### **High-pressure laminate, plywood edge**

Black



#### **Mass-colored wood fibreboard**

Grey



Black



### **Table frame**

#### **Powder-coated metal**

Jet Black RAL 9005

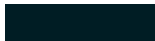

Other finishing options available on request.



Meeter side table

## ELECTRICAL OUTLET

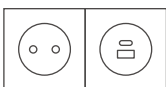

**220V + USB A & C**

Other electrical outlet combinations available on request.

**Berker Integro Flow**  
Color: Anthracite Matt

Available options DK, EU, FR, UK

SAMPLE COMBINATIONS

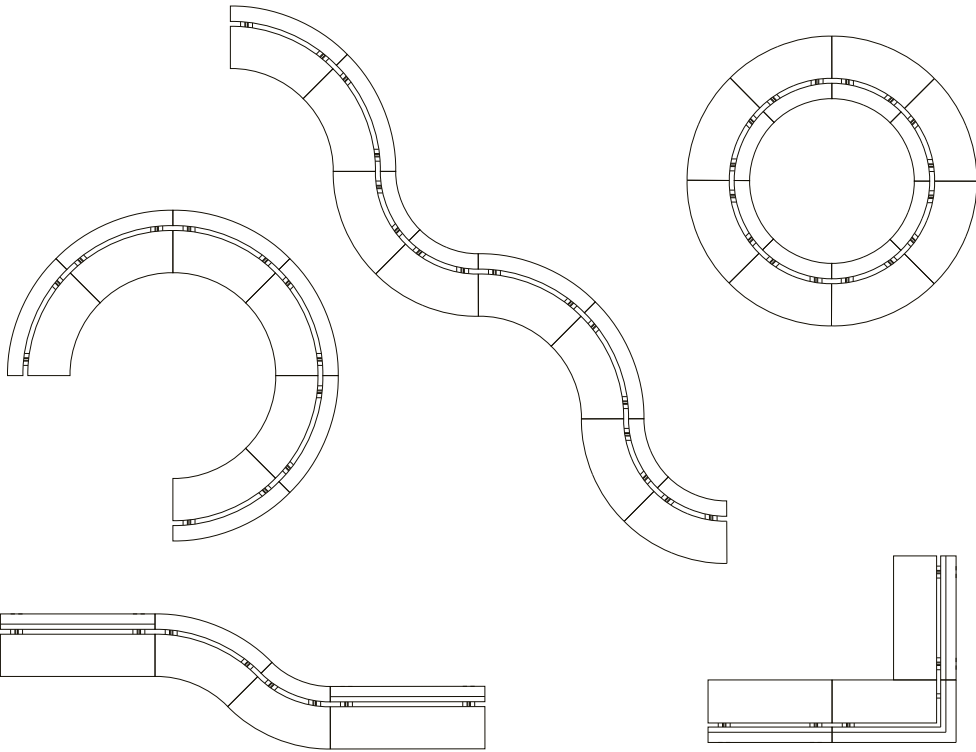



## DIMENSIONS

### Modules

Seat depth: 46 cm / Seat height: 45 cm

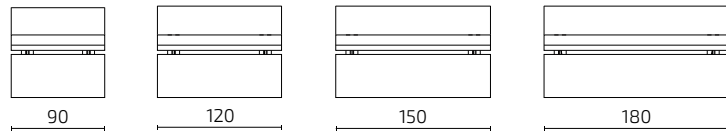
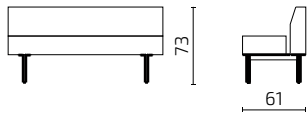

**S83-1**

**S83-2**

**S83-2.5**

**S83-3**

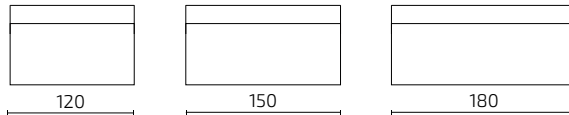

**S83-F1.5**

**S83-F2**

**S83-F3**

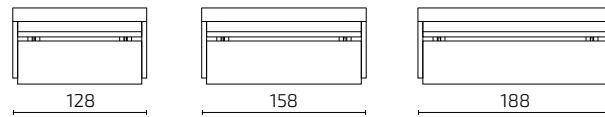
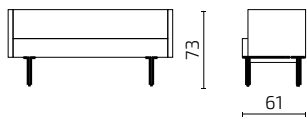

**S83-S1.5**

**S83-S2**

**S83-S3**

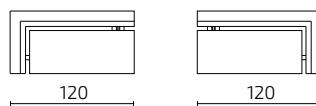
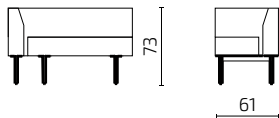

**S83-CL**

**S83-CR**

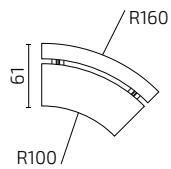
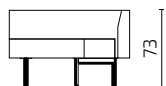

**S83-SR**

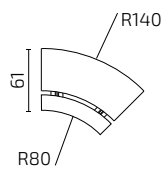
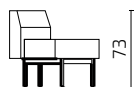

**S83-VR**

### Table



**S108-T1**

All dimensions provided in centimetres.

# Meeter Round

## Sofa modules

Design: Argo Tamm

Meeter Round, an evolution of the straight module, streamlines rows of seating. Its gently rounded silhouette and smooth curves optimise available space, creating an inviting seating area perfect for waiting rooms, cafés, and other public spaces.



Welcome Zone



Social Zone

Create compact waiting spots

Add elegance with a rounded silhouette

## PRODUCT INFORMATION

### Versions

Available in 3 different heights and 2 different shapes

### Modularity

Modules can be connected together

### Legs

Available with regular legs and plinth

### Accessories

Attached side table to add functionality

### Warranty

5 years

### Sustainability

Based on principles of the circular economy

### Certification



## STANDARD MATERIALS

### Frame

Solid wood and plywood

### Seat & backrest

Durable HR foam; fire retardant HR foam on request

### Legs

Solid oak / Powder-coated metal

Plinth: Veneer / High-pressure laminate

### Table

Mass colored wood fibreboard / high-pressure laminate top with plywood edge; powder-coated metal frame

### Fabric upholstery

The cover material is not removable

Choose any fabric from **Intuit Standard Fabric Collection**

### Additional information

As part of after-sales service we offer the change of cover fabric and all other components if needed



## LEGS



Solid oak legs, stained and varnished; anti-slip soles





Powder-coated metal; anti-slip soles. Available in U-shape and straight legs



Plinth  
Additional cost will apply

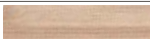
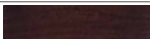

### **Solid oak**

Whitened	
Natural	
Wenge	
Black	

### **Powder-coated metal**

Jet Black RAL 9005	
--------------------	---

### **Plinth**

Natural oak veneer	
Black high-pressure laminate	

Other finishing options available on request.

## TABLE

### **Tabletop**

#### **High-pressure laminate, plywood edge**

Black	
-------	---

#### **Mass-colored wood fibreboard**

Grey	
Black	

### **Table frame**

#### **Powder-coated metal**

Jet Black RAL 9005	
--------------------	---



Meeter side table

Other finishing options available on request.

## DIMENSIONS

### Modules

Seat depth: 45 cm / height: 46 cm

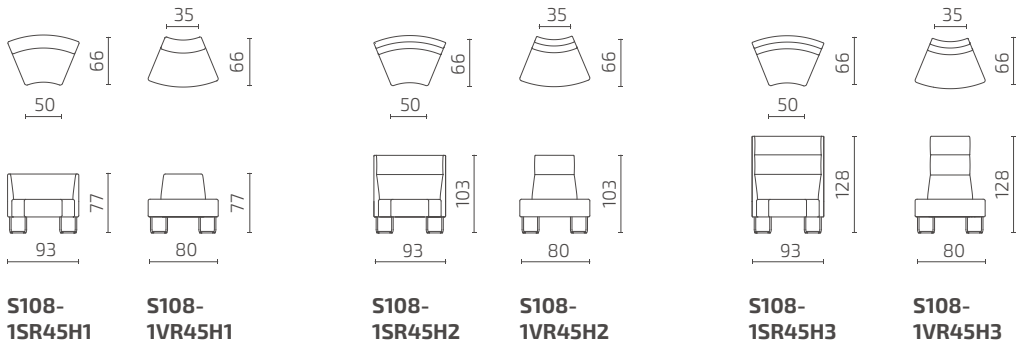

All dimensions provided in centimetres.

### Table



S108-T1

## SAMPLE COMBINATIONS

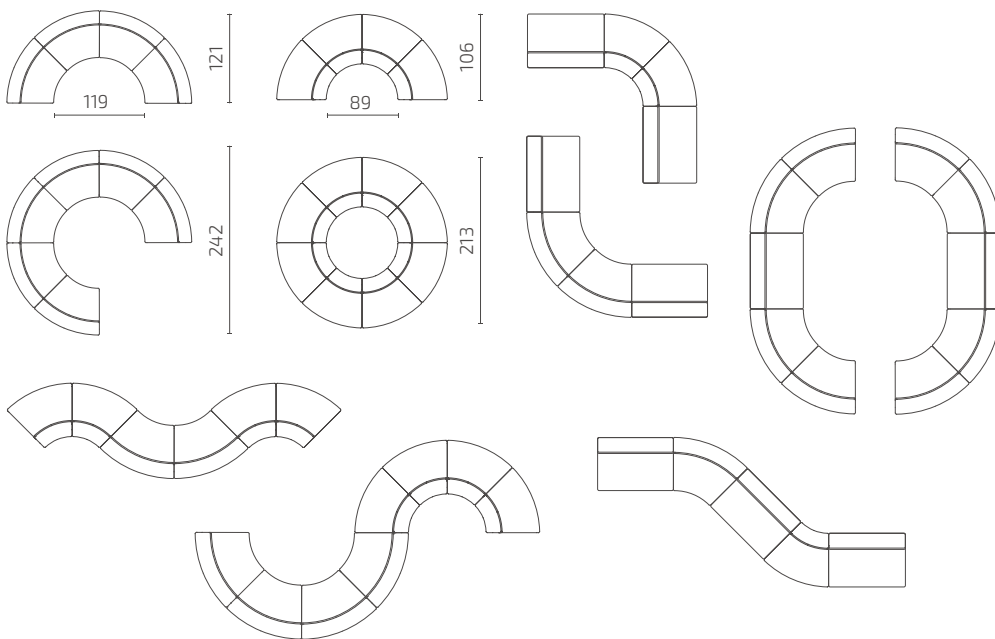

Round module with inner radius / H3

Round module with outer radius / H3

# Meeter Sofa & Armchair

## Sofa and armchair

Design: Argo Tamm

The modern, simple lines of the Armchair & Sofa come in standard dimensions. Available in three widths, the modules seat one, two, or three people side by side. Choose from three backrest heights – the higher, the more private.



Welcome Zone



Social Zone

Create compact waiting spots

Elevate privacy with stylish high walls

## PRODUCT INFORMATION

### Versions

Available in 3 different heights and 3 different sizes

### Legs

Available with regular legs and plinth

### Accessories

Attached side table to add functionality  
Custom-made planter boxes to offer an organic touch of privacy

### Electrical outlet

Integrated electrical outlet

### Warranty

10 years

### Sustainability

Based on principles of the circular economy

### Test & Certification

- L2 European Standard strength, durability and safety certificate
- EU Ecolabel Certified



## STANDARD MATERIALS

### Frame

Solid wood and plywood

### Seat & backrest

Durable HR foam; fire retardant HR foam on request

### Legs

Solid oak / Powder-coated metal  
Plinth: Veneer / Melamine / High-pressure laminate

### Tables

Mass colored wood fibre board / high-pressure laminate top with plywood edge; powder-coated metal frame

### Planter box

Veneer / Melamine / High-pressure laminate

### Fabric upholstery

The cover material is not removable  
Choose any fabric from **Intuit Standard Fabric Collection**

### Additional information

As part of after-sales service we offer the change of cover fabric and all other components if needed



## LEGS



Solid oak legs, stained and varnished; anti-slip soles





Powder-coated metal; anti-slip soles. Available in U-shape and straight legs



Plinth  
Additional cost will apply

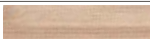
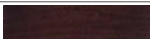

### **Solid oak**

Whitened	
Natural	
Wenge	
Black	

### **Powder-coated metal**

Jet Black RAL 9005	
--------------------	---

### **Plinth**

Natural oak veneer	
Black melamine	
Black high-pressure laminate	

Other finishing options available on request.

## TABLE

### **Tabletop**

#### **High-pressure laminate, plywood edge**

Black	
-------	---

#### **Mass-colored wood fibreboard**

Grey	
Black	

### **Table frame**

#### **Powder-coated metal**

Jet Black RAL 9005	
--------------------	---



Meeter side table

Other finishing options available on request.

## PLANTER BOX

Natural oak veneer



Black melamine



Black high-pressure laminate



Other finishing options available on request.

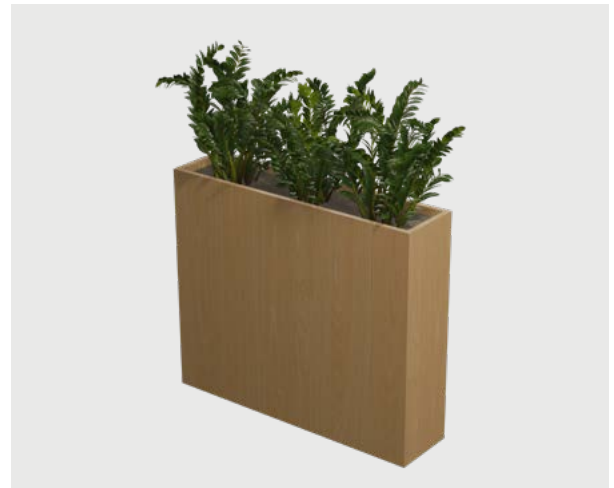

## ELECTRICAL OUTLET

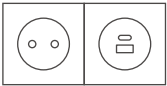

**220V + USB A & C**

Other electrical outlet combinations available on request.

**Berker Integro Flow**

Color: Anthracite Matt

Available options DK, EU, FR, UK





Armchair / H1



Armchair / H2



Armchair / H3



Sofa 2-Seat / H1



Sofa 2-Seat / H2



Sofa 2-Seat / H3



# DIMENSIONS

## Armchair and sofa

Seat depth: 45 cm / Seat height: 46 cm

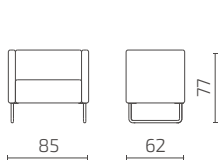

**S108-S1H1**

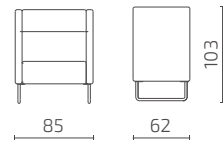

**S108-S1H2**

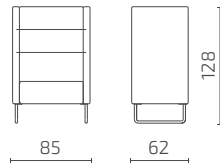

**S108-S1H3**

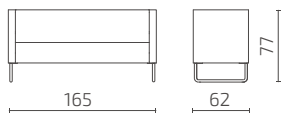

**S108-S2H1**

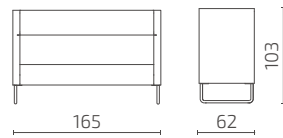

**S108-S2H2**

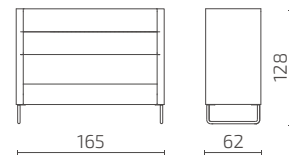

**S108-S2H3**

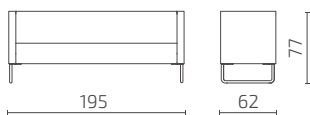

**S108-S3H1**

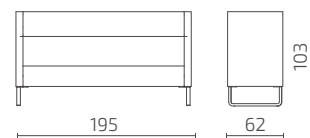

**S108-S3H2**

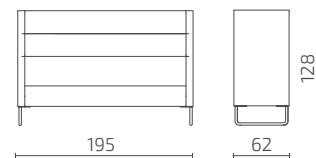

**S108-S3H3**

All dimensions provided in centimetres.

## Table



**S108-T1**

## Planter boxes

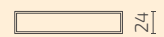
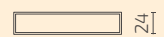
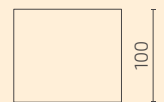
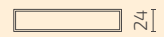
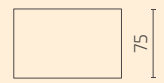

Length tailored to Meeter sofa

## Inner dimensions

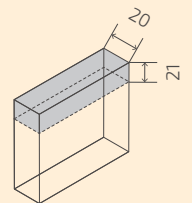

# Meeter Workbay

## Workstation

Design: Argo Tamm

The calm walls of the Meeter Workbay can contain the most important of conversations, or welcome the individual in for some deep focused work. We've all found the need for quiet and calm in the middle of a busy workplace. That's why we're helping you create the perfect Concentration Zone.

Meeter Workbay's minimalist design makes it an easy addition to any open-plan office, letting you create the private spaces you need.



Collaboration Zone



Concentration Zone

Divide your space organically

Give the option of focus and seclusion

Cut down on background noise

Hold your own private meeting

## PRODUCT INFORMATION

### Versions

Available in 3 different sizes

### Legs

Available with regular legs and plinth

### Accessories

Additional tables to add functionality to the seating area

### Electrical outlet

Integrated electrical outlet

### Warranty

5 years

### Sustainability

Embraces the principles of circular design

### Test & Certification

- L1 European Standard strength, durability and safety certificate
- EU Ecolabel Certified



## STANDARD MATERIALS

### Frame

Solid wood and plywood

### Seat & backrest

Durable HR foam; fire retardant HR foam on request

### Wall fastenings

Powder-coated metal

### Legs

Solid oak / Powder-coated metal

Plinth: Veneer / Melamine / High-pressure laminate

### Tables

Matt high-pressure laminate top with powder-coated metal legs

### Fabric upholstery

The cover material is not removable

Choose any fabric from **Intuit Standard Fabric Collection**

### Additional information

As part of after-sales service we offer the change of cover fabric and all other components if needed

Finnish Transport Infrastructure Agency in Helsinki, Finland. Photo: Hannakaisa Pekkala



## LEGS



Solid oak legs, stained and varnished; anti-slip soles







Powder-coated metal; anti-slip soles. Available in U-shape and straight legs



Plinth  
Additional cost will apply

### **Solid oak**



Whitened	
Natural	
Wenge	
Black	

Other finishing options available on request.

### **Powder-coated metal**

Jet Black RAL 9005	
--------------------	---





### **Plinth**

Natural oak veneer	
Black melamine	
Black high-pressure laminate	

## TABLES



### **Aide tabletop**

#### **High-pressure laminate**

Alpine White Egger W1100 PM	
Soft Black Egger U999 PM	
Stone Green Egger U665 PM	
Garnet Red Egger U399 PM	

### **Aide table legs**

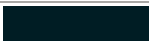
#### **Powder-coated metal**

Signal White RAL 9003	
Jet Black RAL 9005	
Tarpaulin Grey RAL 7010	
Black Red RAL 3007	

Other finishing options available on request.



## ELECTRICAL OUTLET

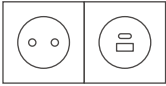

**220V + USB A & C**

**Berker Integro Flow**  
Color: Anthracite Matt

Available options DK, EU, FR, UK

Other electrical outlet combinations available on request.

## DIMENSIONS

### Workbay

Seat height: 46 cm

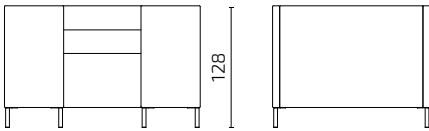

**S108-WS1H3**

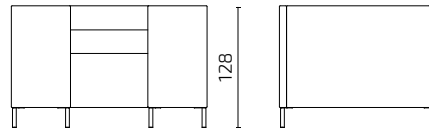

**S108-WS2H3**

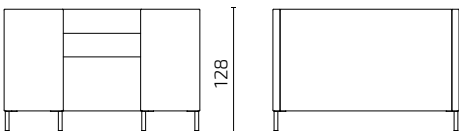
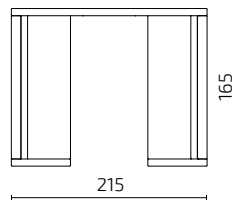
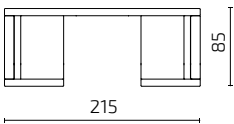

**S108-WS3H3**

All dimensions provided in centimetres.

## Tables

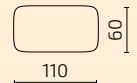
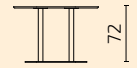

**S128-T1M**  
AIDE table

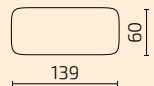
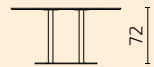

**S128-T3M**  
AIDE table



# Node

## Modular sofa system

Design: Argo Tamm

Designed for larger public interiors where flexibility, presence and spatial structure must work together, Node is a modular sofa system created to shape central spaces with confidence. Developed as a natural evolution of Intuit's highly versatile Meeter series, Node expands the same core strengths into a larger, more expressive format — offering greater comfort, stronger visual presence and broader planning potential for spacious environments.



Welcome Zone



Social Zone



Collaboration Zone

Shape larger environments with flexibility

Build inviting spaces that adapt

Create central spaces

## PRODUCT INFORMATION

### Versions

Available in 2 heights and 4 lengths  
Straight and inward and outward-facing curved modules

### Modularity

Modules can be connected together

### Legs

Black plastic

### Accessories

Attached side table to add functionality

### Electrical outlet

Integrated in the table top

### Warranty

5 years

### Certification



## STANDARD MATERIALS

### Frame

Plywood, high density fiberboard

### Seat & backrest

Durable HR foam; fire retardant HR foam on request

### Table

Mass colored MDF / high-pressure laminate top;  
powder-coated metal frame

### Fabric upholstery

The cover material is not removable

Choose any fabric from **Intuit Standard Fabric Collection**

### Additional information





As part of after-sales service we offer the change of cover fabric and all other components if needed



## FINISHING OPTIONS

### Tabletop

#### *High-pressure laminate*

Alpine White Egger W1100 PM	
Soft Black Egger U999 PM	
Stone Green Egger U665 PM	
Garnet Red Egger U399 PM	

#### *Mass-colored MDF*

Natural	
---------	---

### Table frame

#### *Powder-coated metal*

Jet Black RAL 9005	
--------------------	---

Other finishing options available on request.





**With its modular logic,** Node allows designers to build straight, curved and expansive seating landscapes that adapt to the scale and rhythm of each project. Available in two heights and multiple straight and rounded modules, Node supports everything from open social interaction to more defined spatial zoning.

**Its larger form** makes it particularly well suited for foyers, waiting areas, hospitality spaces, educational hubs and public interiors where furniture must do more than provide seating — it defines the atmosphere and creates purposeful gathering points.

# DIMENSIONS

## Straight modules

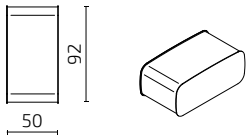
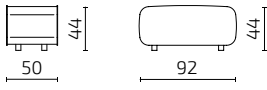

**S84-1F**

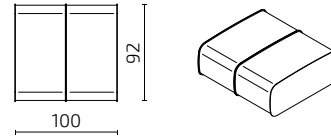
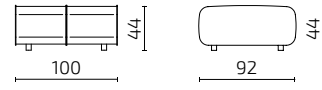

**S84-2F**

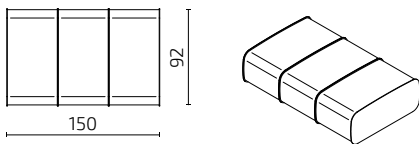
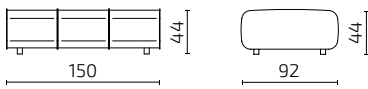

**S84-3F**

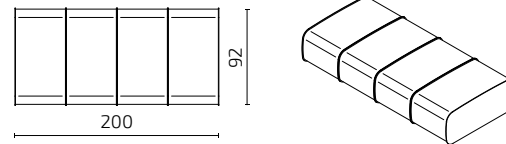
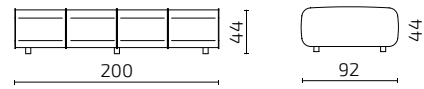

**S84-4F**

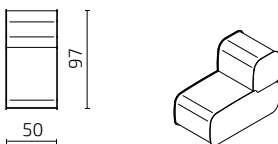
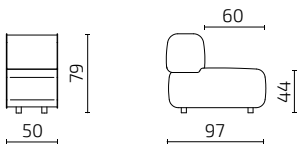

**S84-1SH1**

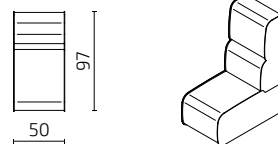
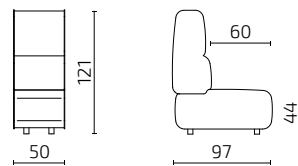

**S84-1SH2**

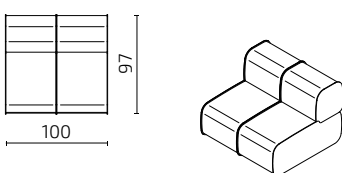
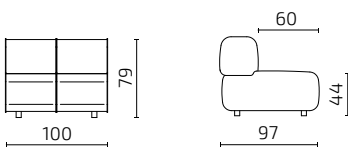

**S84-2SH1**

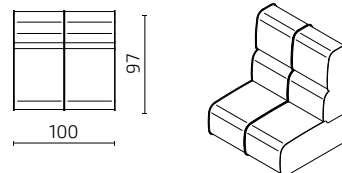
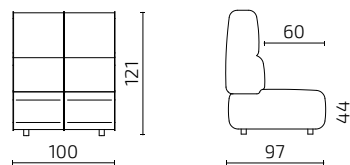

**S84-2SH2**

All dimensions provided in centimetres.

# DIMENSIONS

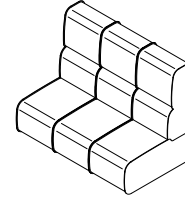
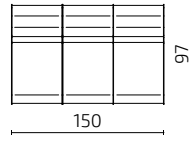
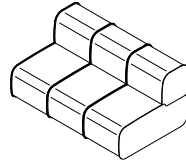
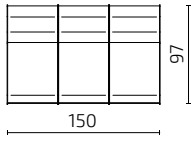
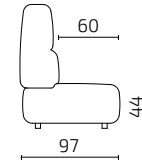
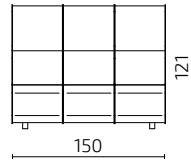
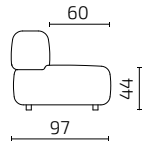
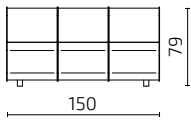

**S84-3SH1**

**S84-3SH2**

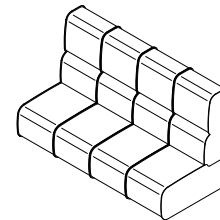
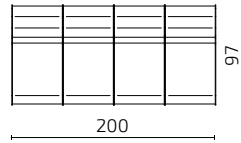
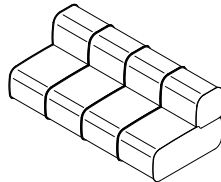
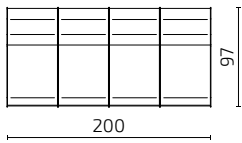
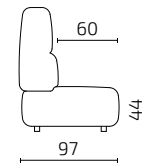
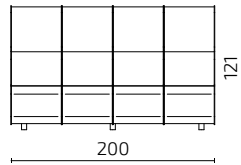
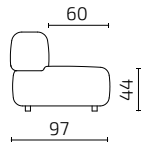
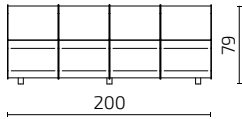

**S84-4SH1**

**S84-4SH2**

## Straight modules with shared backrest

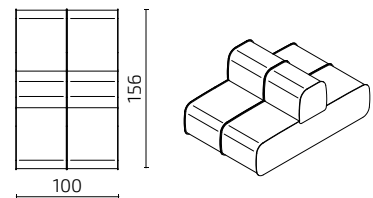
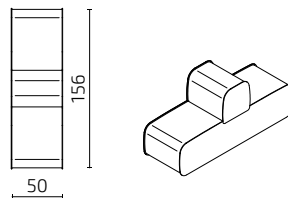
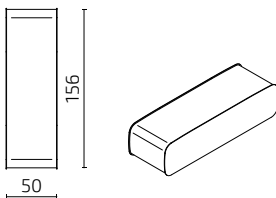
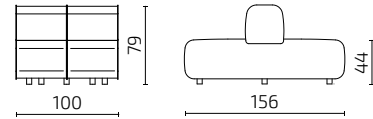
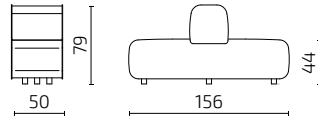
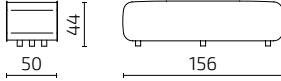

**S84-1S1F**

**S84-11SH1**

**S84-21SH1**

All dimensions provided in centimetres.

**Round modules**

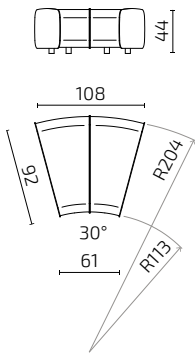

**S84-1RF**

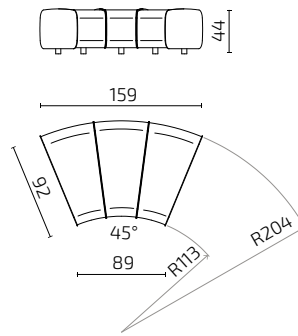
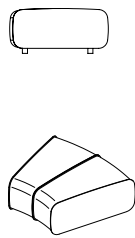

**S84-2RF**

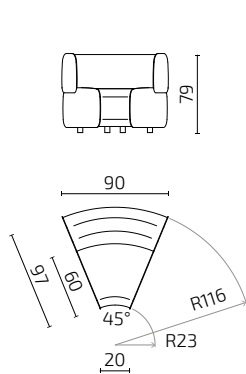
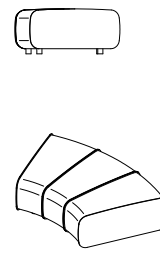

**S84-CH1**

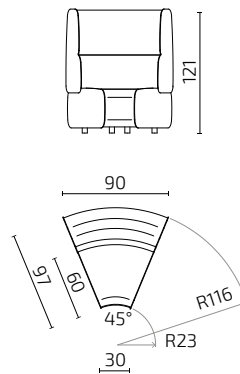
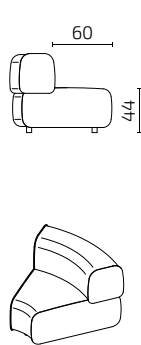

**S84-CH2**

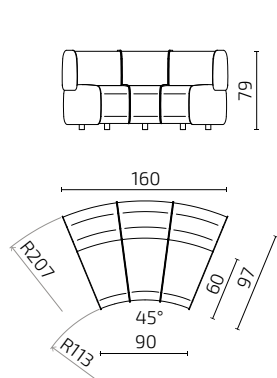
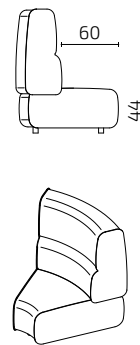

**S84-1SRH1**

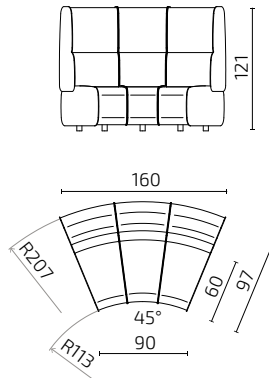
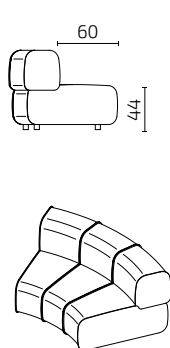

**S84-1SRH2**

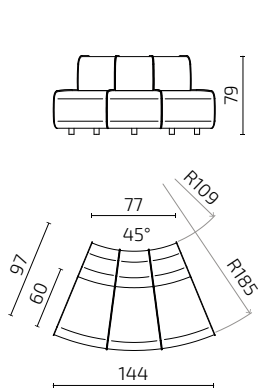
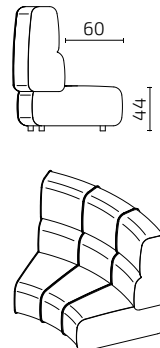

**S84-1VRH1**

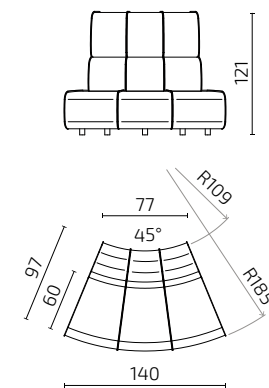
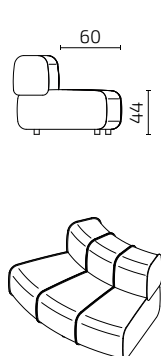

**S84-1VRH2**

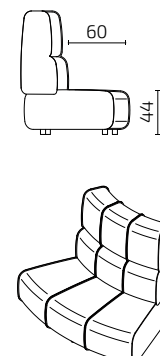

All dimensions provided in centimetres.

**Tables**

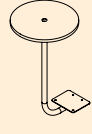
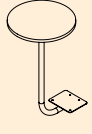
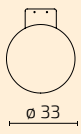
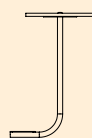
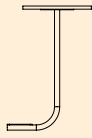
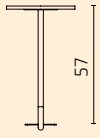

**S84-T1**

**S84-T1E**



# Sans

## Soft work sofa

Design: Argo Tamm

The Sans versatile sofa family provides a welcoming resting place in the welcome and social areas. Comfortable and practical for a communal space, the Sans is available as a classic sofa, or with an integral table. And, when equipped with eye-level walls, it's the perfect home for intimate conversations in any breakout spaces. Pop down your coffee cup, lean back, and enjoy the clean lines and sociable layout.



Welcome Zone



Social Zone



Collaboration Zone

Divide your space organically

Offer up moments of rest and relaxation

Make your visitors feel at home

## PRODUCT INFORMATION

### Versions

Many different sizes and combinations

### Accessories

Various additional tables  
Additional pillows

### Electrical outlet

Under the seating mounted to the frame  
Integrated in the table top

### Warranty

5 years

### Sustainability

Based on principles of the circular economy

### Test & Certification

L1 European Standard strength, durability and safety certificate



## STANDARD MATERIALS

### Frame

Solid wood and plywood

### Seat & backrest

Durable and fireproof HR-foam; nosag springs; fixed seat and back cushions

### Legs

Powder-coated metal frame; plastic soles

### Tables

High-pressure laminate table top with plywood edge, powder-coated metal frame

### Pillows

Feather filling

### Fabric upholstery

The cover material is not removable

Choose any fabric from **Intuit Standard Fabric Collection**

### Additional information

As part of after-sales service we offer the change of cover fabric and all other components if needed

Co-working space NUUUORK at Berlin Airport, Germany. Photo: Ariane Brille



## FINISHING OPTIONS

### Leg frame

#### *Powder-coated metal*

Jet Black RAL 9005



### Tabletop

#### *High-pressure laminate, plywood edge*

Black



### Table frame

#### *Powder-coated metal*

Jet Black RAL 9005



Other finishing options available on request.



## ELECTRICAL OUTLET

### Under the seating attached to the frame

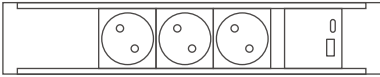

**3x 220V + USB A & C**

### **Bachmann Power Strip**

Color: Black Matt

*Available options DK, EU, FR, UK*

### Integrated in the table top



**220V + USB A**

### **Powerdot Compact 61**

Color: Black Matt

*Available options EU, FR, UK*

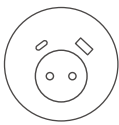

**220V + USB A & C**

### **Powerdot 16**

Color: Black Matt

*Available options DK, EU, FR*

Other electrical outlet combinations available on request.

Savant Zorg office in the Netherlands



SAMPLE COMBINATIONS

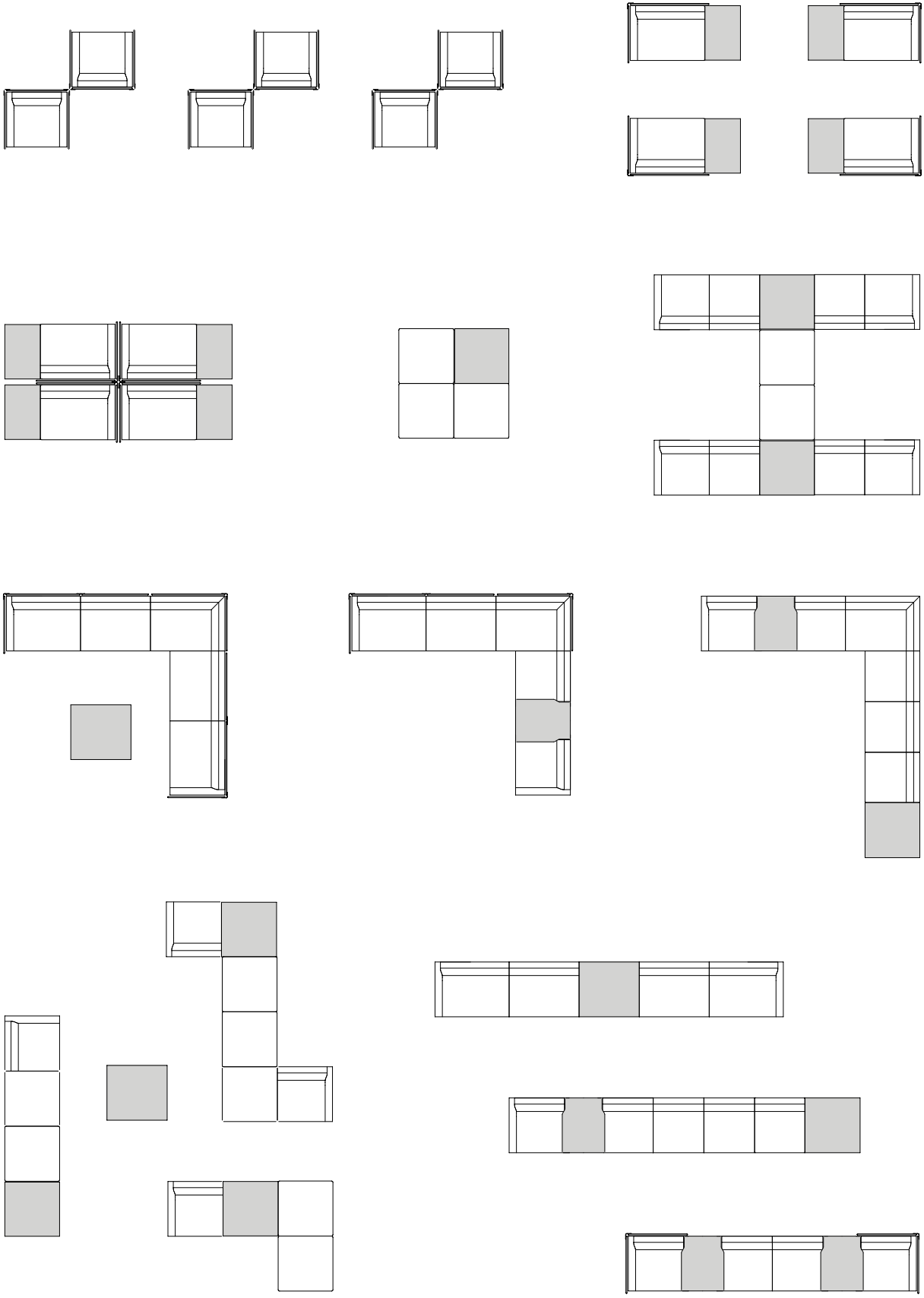



# DIMENSIONS

## Individual modules

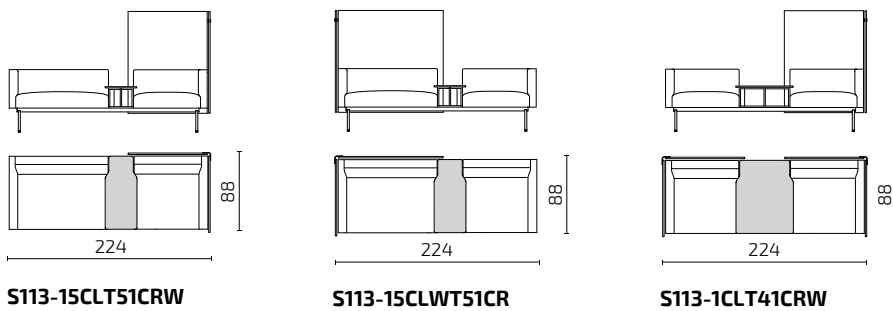
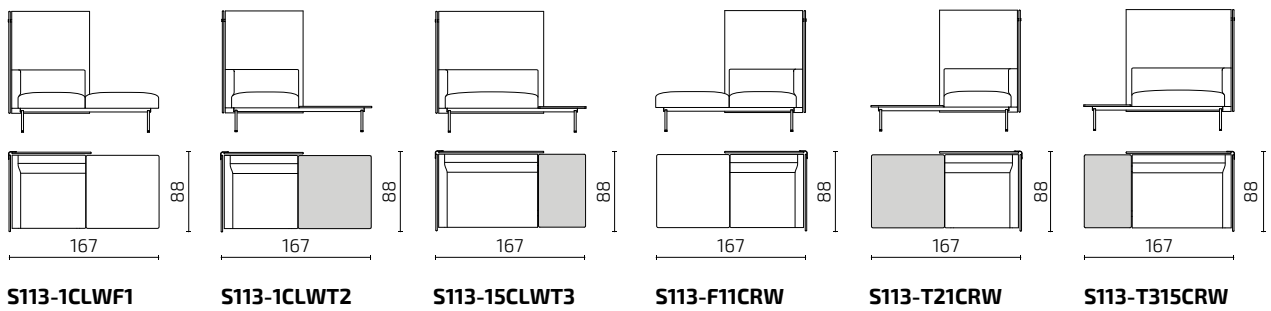
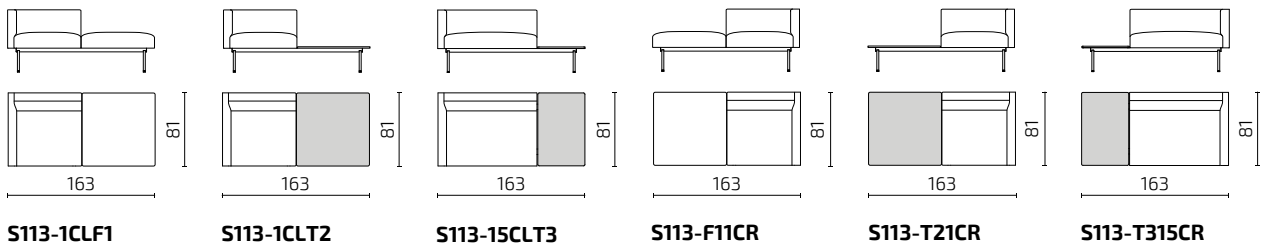
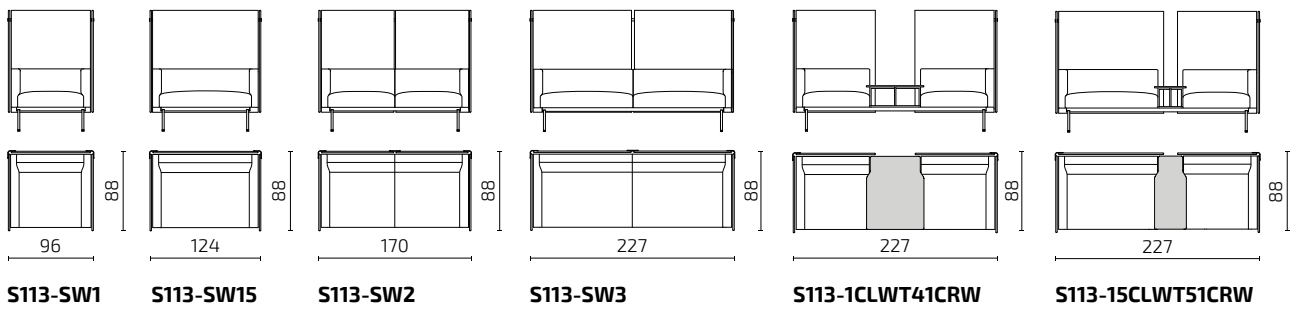
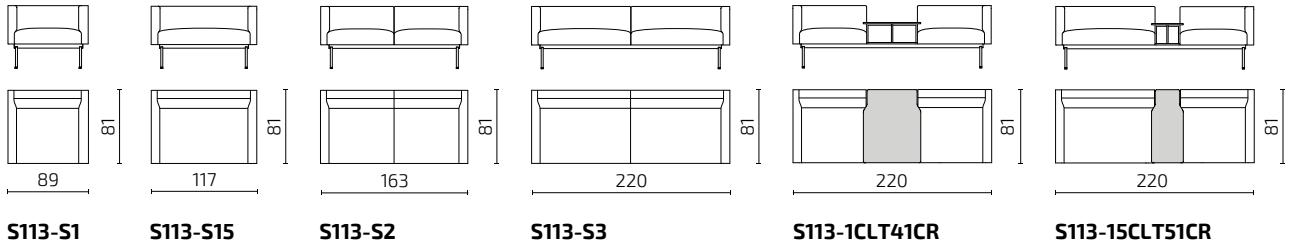
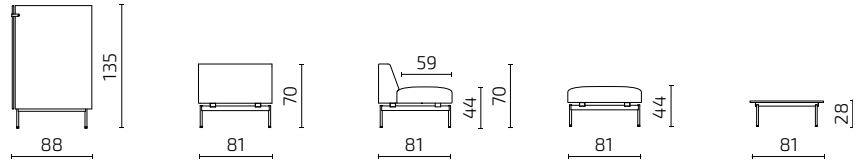

## DIMENSIONS

### Daybed

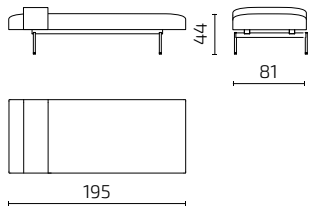

**S113-DB1**

### Poufs and tables

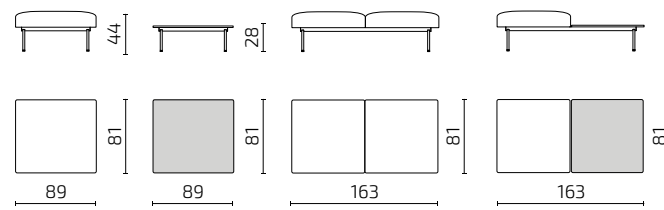

**S113-F**

**S113-T1**

**S113-F2**

**S113-F1T2**

### Pillows

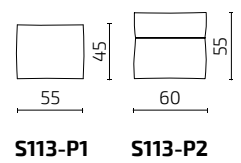

**S113-P1**

**S113-P2**

### Modules to combine

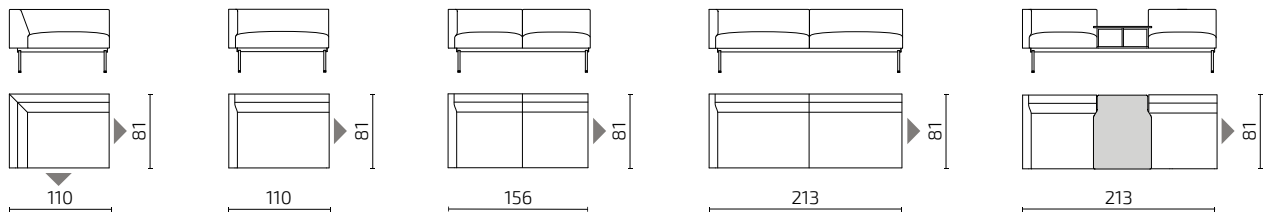

**S113-CL**

**S113-15CL**

**S113-2CL**

**S113-3CL**

**S113-1CLT41**

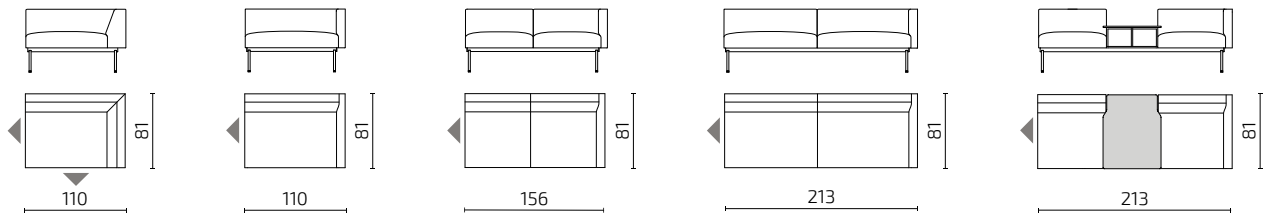

**S113-CR**

**S113-15CR**

**S113-2CR**

**S113-3CR**

**S113-1T41CR**

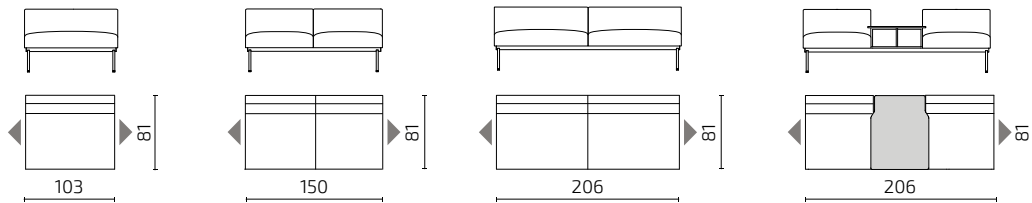

**S113-15**

**S113-2**

**S113-3**

**S113-1T41**

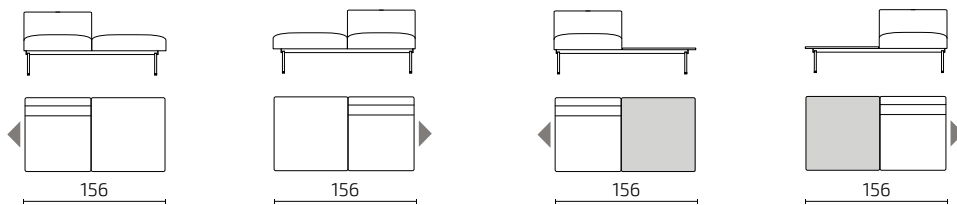

**S113-1F1**

**S113-F11**

**S113-1T2**

**S113-T21**

All dimensions provided in centimetres.

**Modules to combine**

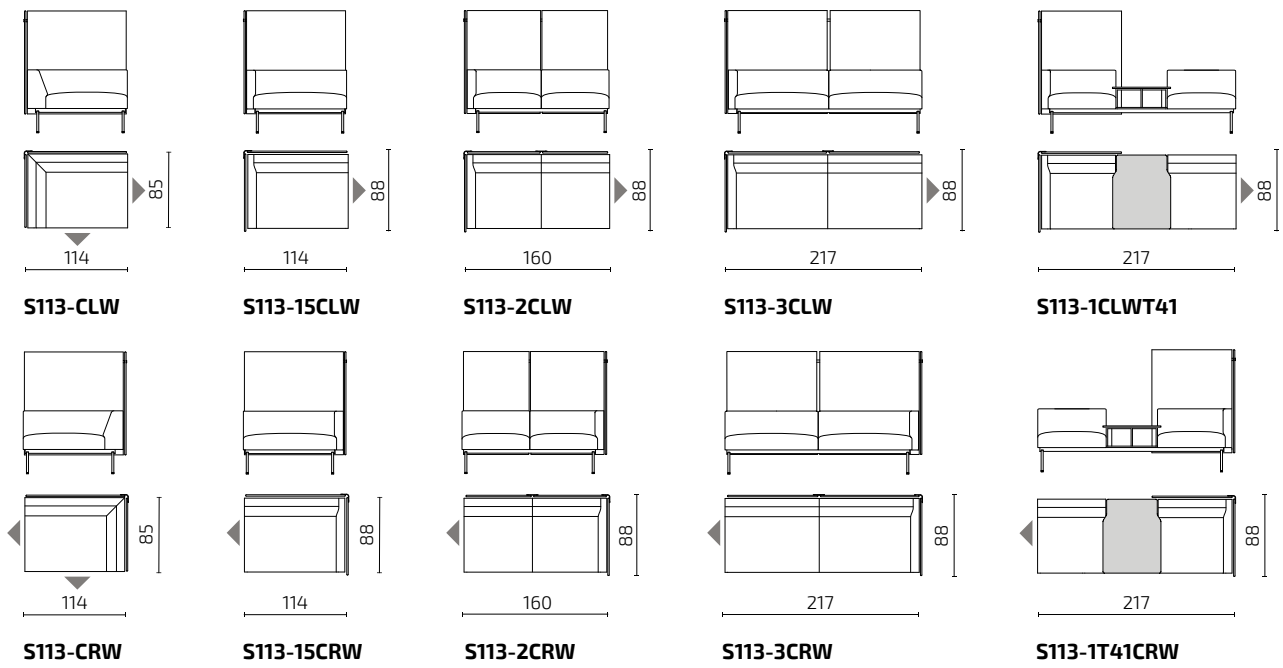

All dimensions provided in centimetres.





# Sofi

Available at  
**pCon**  
PLANNER

## Sofa & pouf system

Design: Janno Nõu, Iseasi

Kick back and relax. With their fresh look and slim proportions, the Sofi sofa and pouf make even the smallest Welcome Zones inviting. Your visitors will want to put their feet up and settle in with a coffee – so comfy they won't even mind if you're a little late!



Welcome Zone

Create cosy spots in even the smallest spaces

Move around as the conversation flows

Make your guests feel at home

## PRODUCT INFORMATION

### Versions

Available as a sofa, bench and 2 pouf shapes

### Warranty

5 years

### Sustainability

Based on principles of the circular economy

### Certification



## STANDARD MATERIALS

### Frame

Solid wood and plywood

### Seat & backrest

Durable HR foam; fire retardant HR foam on request

### Legs

Stained solid oak

### Fabric upholstery

The cover fabric is not removable

Choose any fabric from **Intuit Standard Fabric Collection**

### Additional information

As part of after-sales service we offer the change of cover fabric and all other components if needed

Kääriku Sports Center, Estonia. Photo: Tõnu Runnel



## LEGS

### **Solid oak**

Whitened



Natural



Wenge



Black



Other finishing options available on request.



## DIMENSIONS

Seat depth: 48 cm

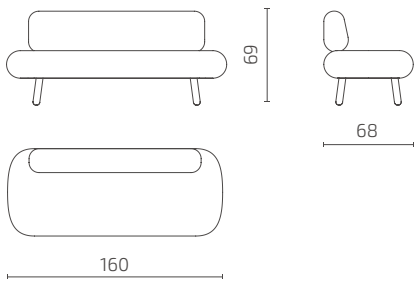

**S105-S2**

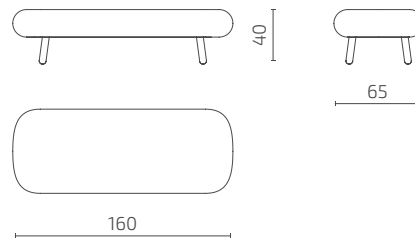

**S105-F2**

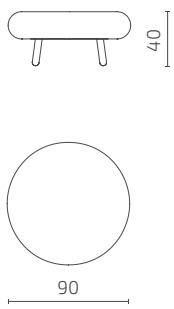

**S105-F90**

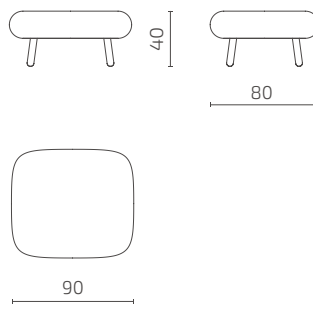

**S105-F1**

All dimensions provided in centimetres.



# Takt

## Complete micro workstation

Design: Lauri Visnapuu

Designed for moments that require focus in shared environments, TAKT is a compact, all-in-one micro workstation that creates a personal work zone wherever it's needed. Combining a comfortable upholstered seat, integrated work surface, lighting and power access within softly enclosing side panels, TAKT supports concentrated work without isolating the user from the surrounding space.

Ideal for modern offices, libraries, educational facilities and public interiors, TAKT offers a flexible solution for work nomads, hybrid employees and visitors who need a quiet place to read, think or work for a short or extended period. Its modular logic allows units to be placed individually or in rhythmic rows, adapting seamlessly to different layouts and space constraints.



Concentration Zone

Encourage focus and privacy

Divide your space with ease

Reduce visual distractions

## PRODUCT INFORMATION

### Versions

1- or 1,5-seat modules; left- or right-handed seat position

### Electrical outlet

Integrated in the table top

### Lighting

Integrated to the wall panel

### Warranty

5 years

### Sustainability

Designed according to circular economy principles. All components are easily replaceable, supporting long product life and responsible use

### Certification



## STANDARD MATERIALS

### Walls

Laminated chipboard, partially covered without fabric upon request

### Wall frame

Solid ash wood

### Table

Laminated birch plywood table top with powder-coated metal frame

### Seat

Durable HR foam; fire retardant HR foam on request

### Seat legs

Solid ash wood

### Cushions

Feather filling, attached with velcro

### Fabric upholstery

Removable covers are attached with velcro

Choose any fabric from **Intuit Standard Fabric Collection**

### Additional information

As part of after-sales service we offer the change of cover fabric and all other components if needed



## FINISHING OPTIONS



Natural leg finish, anti-slip soles



Black leg finish, anti-slip soles

### Seat legs

#### *Solid ash, stained and lacquered*

Natural	
Black	

Other finishing options available on request.

### Walls

#### *Laminated chipboard, lacquered*

Natural ash	
-------------	---

### Wall frame

#### *Solid ash, lacquered*

Natural	
---------	---

### Table top

#### *Birch plywood, laminated*

Natural	
---------	---

Other finishing options available on request.



## ELECTRICAL OUTLET



#### **Powerdot Compact 61**

Color: Black Matt

Available options EU, FR, UK

**220V + USB A**



#### **Powerdot 16**

Color: Black Matt

Available options DK, EU, FR

**220V + USB A & C**

Other electrical outlet combinations available on request.

## LIGHTING



Black



White

Material: Metal  
 Switch On/Off  
 LED GU10 1x10W 230V

Other finishing options available on request.

## DIMENSIONS

Seat height: 50 cm / Seat depth: 42 cm, without pillow 60 cm

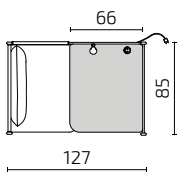
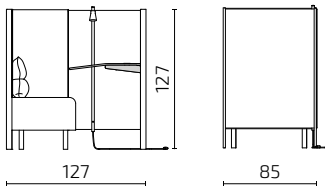

**S80-1SL**

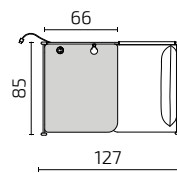
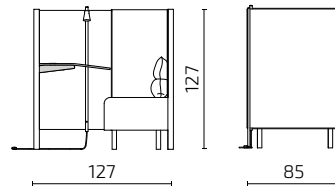

**S80-1SR**

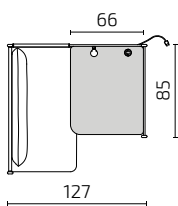
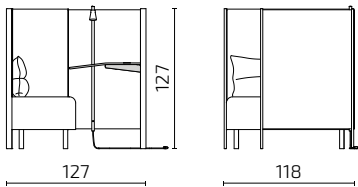

**S80-1,5SL**

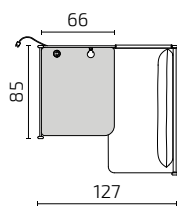
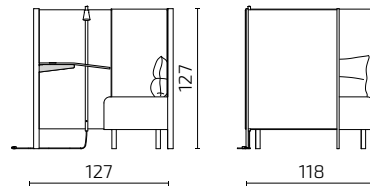

**S80-1,5SR**

All dimensions provided in centimetres.

# Wander

## Cosy niche sofa

Design: Lauri Visnapuu

When you combine the comfort of a home sofa with the convenience of an office sofa, you get Wander – a cosy niche sofa with high walls that provides visual separation, supports productivity, and can be easily moved around.

With modules available in three different widths, Wander offers a number of interior design options. By placing the modules opposite each other, the result is a cosy nest suitable for a private chat. When complemented with an auxiliary desk, it serves as a functional work island. Equipped with castors, Wander moves with you. Modules arranged in a row are also suitable, for a café, for example.

Wander's soft back cushions are loose and adjustable. In keeping with circular economy design, Wander's coverings are durable and easy to replace, even on your own.



Welcome Zone



Social Zone



Collaboration Zone



Concentration Zone

Can be moved around, if desired

Help make waiting more comfortable

Allows you to focus and separate

## PRODUCT INFORMATION

### Versions

Available in 3 different sizes. Additionally available as Workbays in 3 different sizes when connected with compound wall

### Legs

Lockable 360° rotating castors

### Accessories

Workbays' compound walls are equipped with tables to add functionality to the seating area

### Electrical outlet

Integrated electrical outlet

### Warranty

5 years

### Sustainability

Based on principles of the circular economy

### Certification



## STANDARD MATERIALS

### Frame

Solid wood and plywood

### Seat and backrest

Durable HR foam; fire retardant HR foam on request

### Tables

Matt high-pressure laminate top with powder-coated metal leg

### Pillows

Feather filling, attached with Velcro

### Fabric upholstery

The cover fabric is not removable

For extra acoustic attenuation acoustic fabrics recommended  
Choose any fabric from Intuit **Standard Fabric Collection**

### Additional information

As part of after-sales service we offer the change of cover fabric and all other components if needed



## FINISHING OPTIONS

### Tabletop

#### High-pressure laminate

Black



### Table leg

#### Powder-coated metal

Jet Black RAL 9005



Other finishing options available on request.



## ELECTRICAL OUTLET



**220V + USB A & C**

**Berker Integro Flow**  
Color: Anthracite Matt

*Available options DK, EU, FR, UK*

Other electrical outlet combinations available on request.



## DIMENSIONS

Seat depth: 46 cm, without pillow 63 cm

Seat height: 46 cm

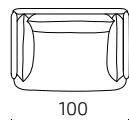
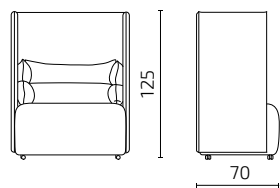

**S129-S1H3**

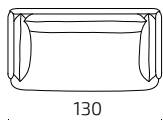
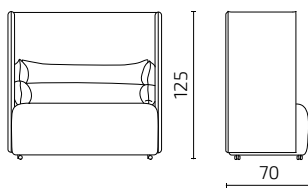

**S129-S2H3**

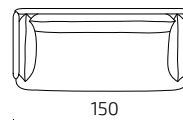
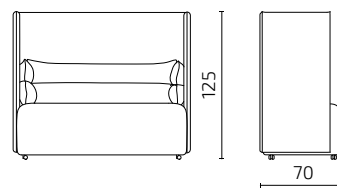

**S129-S25H3**

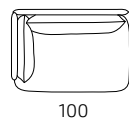
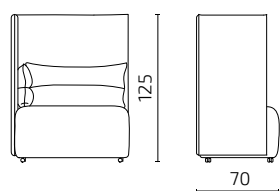

**S129-1CLH3**

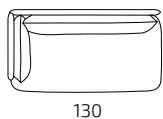
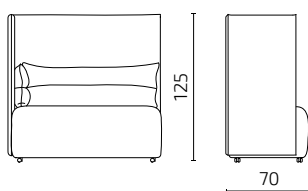

**S129-2CLH3**

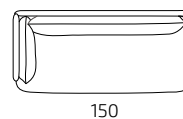
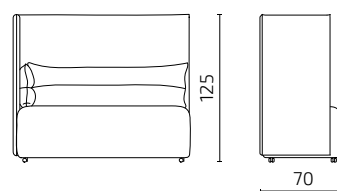

**S129-25CLH3**

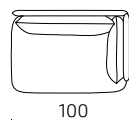
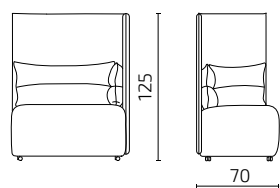

**S129-1CRH3**

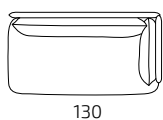
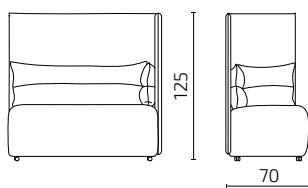

**S129-2CRH3**

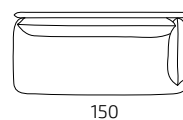
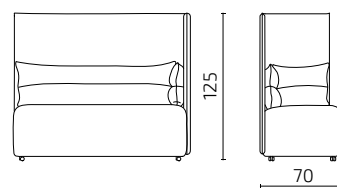

**S129-25CRH3**

### Tables

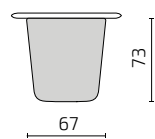
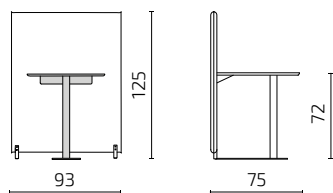

**S129-WH3T1**

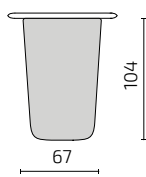
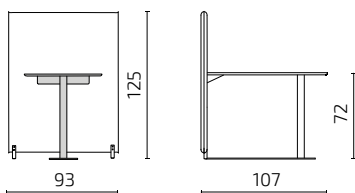

**S129-WH3T2**

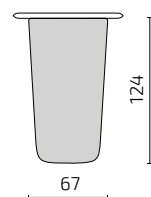
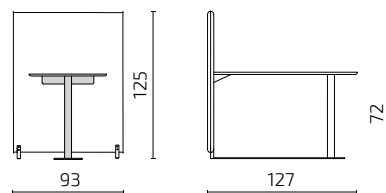

**S129-WH3T25**

All dimensions provided in centimetres.

# Intuit Booth

Available at  
**pCon**  
PLANNER

## Phonebooth

Design: Iseasi



You need to make a call. But you'd rather the whole office didn't listen in. Booth provides a quiet oasis, so you can focus on your conversation, without distractions.

We saw an opportunity to make the basic phone booth a much more pleasant place to be. If you've spent time in cramped and claustrophobic phone booths before, you'll marvel at how Booth opens up the space. You can be part of the open-plan space, while still having access to the focus and privacy you need at various points of your day. And its rocking and rotating seat gives you room to move, without banging your elbows on the walls every 5 seconds.

Booth harnesses technology and design to provide an intuitive space for your special task. With sound absorbing upholstery and acoustic panels, Booth dampens noise from every direction. Its motion sensor fresh air ventilation system and adjustable LED lighting help you create exactly the environment you work well in. While its wheels mean you can relocate it to anywhere in your office.



Concentration Zone

Enjoy a room that feels bigger on the inside

Find the peace you need

Take calls without disturbing your team

## PRODUCT INFORMATION

### Acoustics

Sound absorption class A

### Movable

On four wheels underneath, floor adjusters are integrated for levelling

### Integrated ventilation

Airflow rate: when occupied 40l/s; stand-by mode, after 5 mins no occupancy 27 l/s

### Accessories

Bar height perch, 360° swivel and rocking

### Electrical outlet

Integrated electrical outlet

### Warranty

5 years

### Sustainability

Based on principles of the circular economy

### Test & Certification

Sound absorption class B



## STANDARD MATERIALS

### Structure

High-quality plywood, painted black

### Outside

Soft upholstered panels covered with any felt fabric

### Inside

Ceiling and wall panels covered with certified acoustic and fire-retardant felt and fabric

### Floor

Carpet tile in a fishbone pattern

### Glass door and back wall

442 laminated and tempered clear glass with sound control PVB interlayer

### Bar height perch

Durable HR-foam, fabric; powder-coated matt metal legs; tilting base

### Fabric upholstery

Choose any felt from **Intuit Standard felt selection**

### Additional information

As part of after-sales service we offer the change of cover fabric and all other components if needed

Utilitas Wind office in Tallinn, Estonia. Photo: Märt Lillesiim



## INSIDE COVER MATERIALS

### Walls

#### Pressed felt

Dark Grey



Other finishing options available on request.

### Floor

#### Carpet tile

Grey



## ELECTRICAL OUTLET

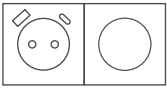

**220V + USB A & C + Dimmer**

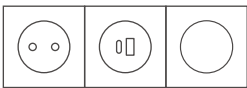

**220V + USB A & C + Dimmer**

### Jung LS

Color: Anthracite Matt

Available options EU, FR

### Jung LS

Color: Anthracite Matt

Available options UK

### Gira

Color: Anthracite Matt

Available options DK

Other electrical outlet combinations available on request.

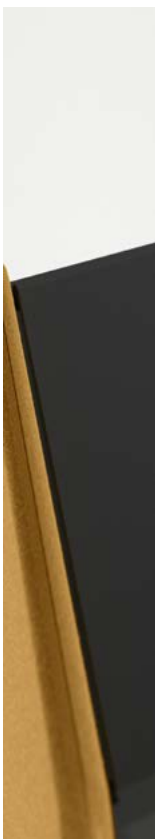

## DIMENSIONS

### Phonebooth

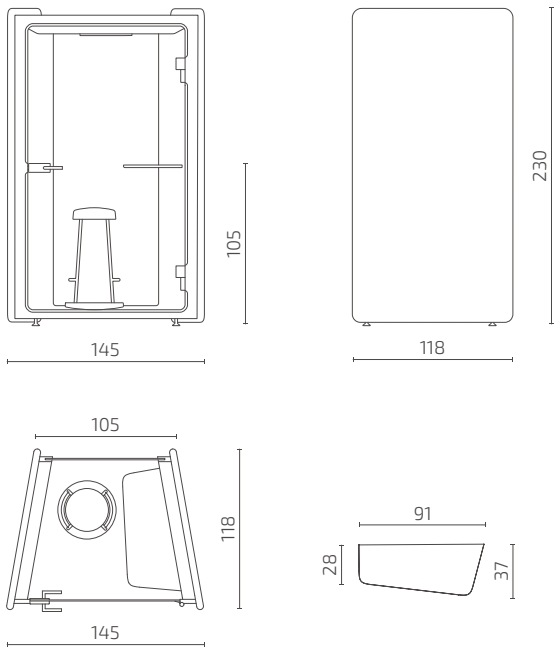

### S122-BOOTH1

All dimensions provided in centimetres.

### Bar height perch

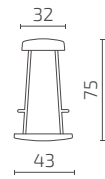

### S122-BFL1

### More Space

Booth's trapezoid shape is especially designed to feel spacious. It enables you to choose different positions. Its wide glass panels help you feel part of your wider surroundings, without being disturbed by them. And make the whole booth full of light. You can swing and turn on your chair, adapting your setup to whatever you need to work on.

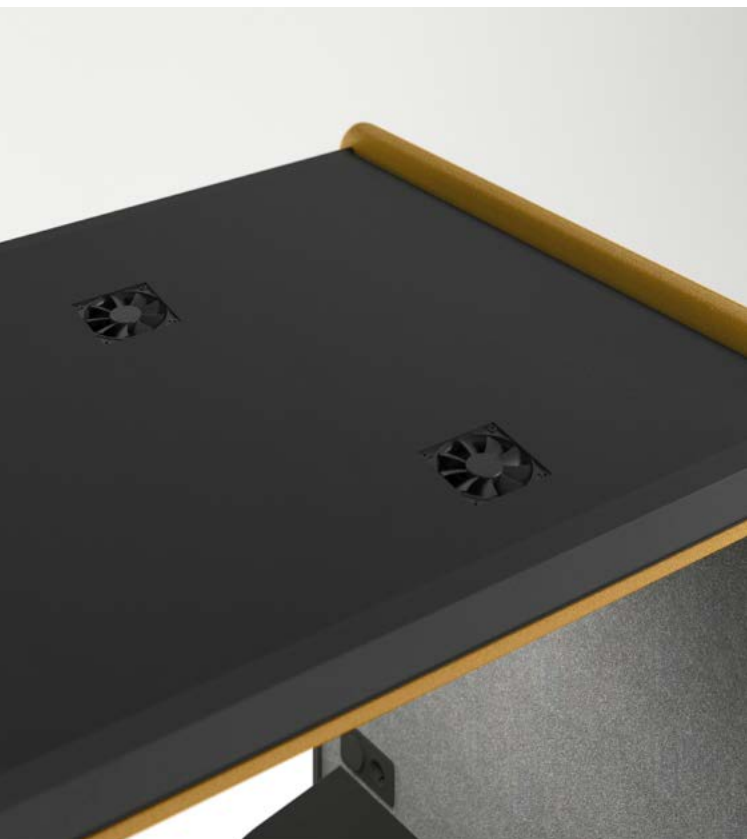

# Aide

## Multifunctional table series

Design: Karl Kukuk

The Aide table is an indispensable backdrop, designed to complement room layouts and core furniture. The multi-functional table series comprises variations that are tall, low, slender, sturdy, spacious, compact, and offer a combination of features, totalling 6 different versions.

With its timeless and refined appearance, Aide blends into any interior, while maintaining an understated presence, allowing other furniture pieces to take the spotlight. Aide focuses on function adapting to various environments – it can be a coffee table in the lounge area, a dining table in cafes and canteens, or a desk in the work zone. Finding the perfect solution is easy, as Aide can be integrated with the entire Intuit soft furniture range.



Welcome Zone



Social Zone



Collaboration Zone



Concentration Zone

Easy to combine with other furniture

Can serve several functions

Always blends stylishly into the interior

## PRODUCT INFORMATION

### Versions

Available in 2 different heights and 3 different sizes

### Warranty

5 years

### Sustainability

Based on principles of the circular economy

### Certification



## STANDARD MATERIALS

### Tabletop

Matt high-pressure laminate

### Legs





Powder-coated metal



## FINISHING OPTIONS



### Tabletop

#### High-pressure laminate

Alpine White Egger W1100 PM	
Soft Black Egger U999 PM	
Stone Green Egger U665 PM	
Garnet Red Egger U399 PM	

### Legs

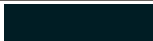
#### Powder-coated metal

Signal White RAL 9003	
Jet Black RAL 9005	
Tarpaulin Grey RAL 7010	
Black Red RAL 3007	



## DIMENSIONS

### Cafeteria or work tables

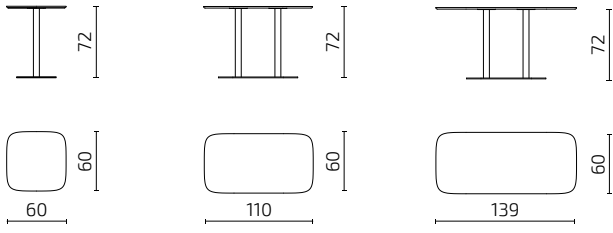

**S128-T4M**

**S128-T1M**

**S128-T3M**

### Sofa tables

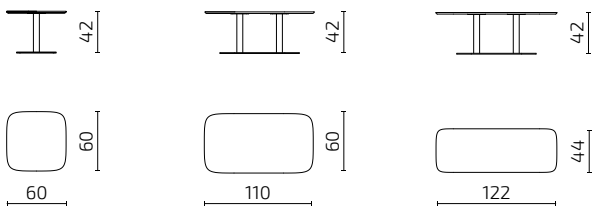

**S128-T4S**

**S128-T1S**

**S128-T3S**

All dimensions provided in centimetres.



# Alfred

## Side table

Design: Argo Tamm

Make it easy for your visitors by giving them somewhere to pop their coffee or the piles of notes resting on their lap.

Add its subtle and stylish design to the smaller Social areas you've dotted around the office, and your team can put down their drinks and connect with a quick midday chat.



Welcome Zone



Social Zone



Collaboration Zone

Break up a row of sofas

Make your spaces inviting and practical

## PRODUCT INFORMATION

### Versions

Available in 2 different heights

### Warranty

5 years

### Sustainability

Based on principles of the circular economy

### Certification



## STANDARD MATERIALS

### Tabletop and leg

Solid wood oak

### Base

Powder-coated metal

## FINISHING OPTIONS

### Tabletop and leg

#### Solid oak

Whitened



Natural



Wenge



Black



### Base

#### Powder-coated metal

Umbra Grey RAL 7022



Jet Black RAL 9005



Other finishing options available on request.



## DIMENSIONS

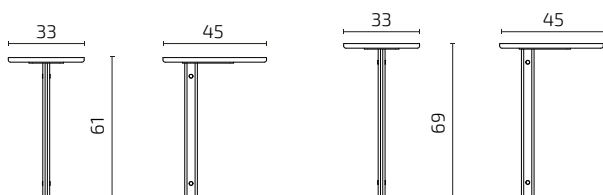

**S61-T61T**

**S61-T69T**

All dimensions provided in centimetres.

# Kuubik

Available at  
**pCon**  
PLANNER

## Sofa table

Design: Argo Tamm

Make it easy. Kuubik is no ordinary table. It's modern cube design means it doesn't impose on its environment.

Use Kuubik to divide up the seating in your reception area, or place them around the office paired with our compact Intro armchair.



Welcome Zone



Social Zone

Bring a little interest to your reception

Encourage inspiring coffee breaks

## PRODUCT INFORMATION

### Versions

Available in 3 different sizes

### Warranty

5 years

### Sustainability

Based on principles of the circular economy

## STANDARD MATERIALS

### Tabletop

Mass-colored wood fibreboard / Veneered MDF board

### Frame

Powder-coated metal

Postimees office in Tallinn, Estonia



## FINISHING OPTIONS

### Tabletop

#### *Veneered MDF board*

Natural oak



#### *Mass-colored wood fibreboard*

Black



### Frame

#### *Powder-coated metal*

Jet Black RAL 9005



Other finishing options available on request.



## DIMENSIONS

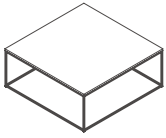

**S56-TLK**

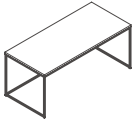
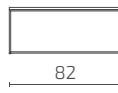
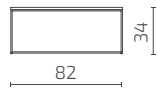

**S56-TMA**

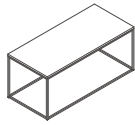
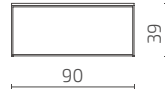

**S56-TMK**

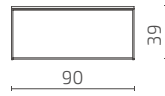

**S56-TSA**

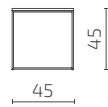

**S56-TSK**

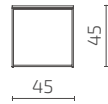

All dimensions provided in centimetres.



# Kuubik

## Side table

Design: Intuit design team

Kuubik side table is a small table of just the right height and weight to pull over your lap while working with the laptop on the couch. The side table is also a comfortable place next to the sofa to place a cup of coffee or a notebook.

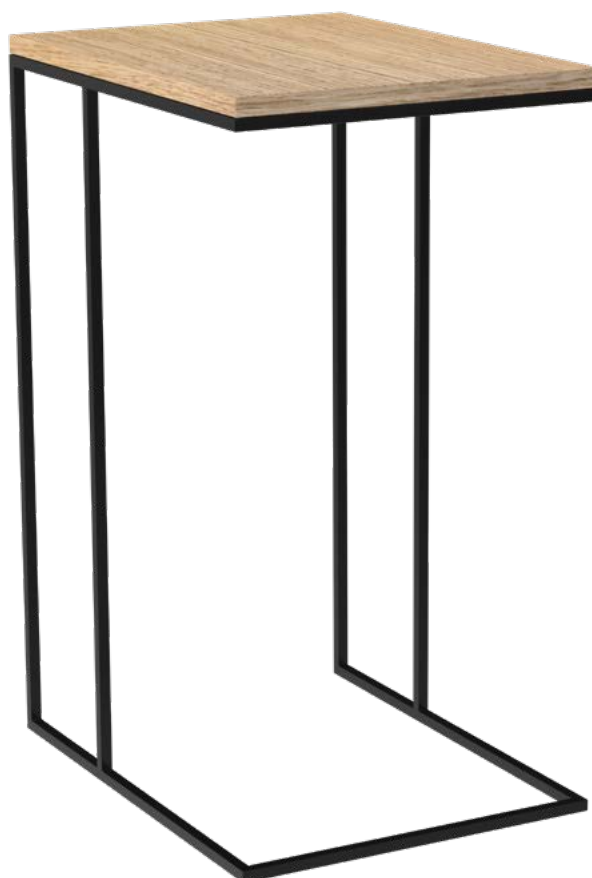

Welcome Zone



Social Zone



Concentration Zone

Give a practical addition to the sofa

Add comfort when working with a laptop on the couch

## PRODUCT INFORMATION

### Versions

Available in 3 different sizes

### Warranty

5 years

### Sustainability

Based on principles of the circular economy

## STANDARD MATERIALS

### Tabletop

Mass-colored wood fibreboard / Veneered MDF board

### Frame

Powder-coated metal

## FINISHING OPTIONS

### Tabletop

#### *Veneered MDF board*

Natural oak



#### *Mass-colored wood fibreboard*

Black



### Frame

#### *Powder-coated metal*

Jet Black RAL 9005

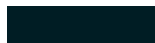

Other finishing options available on request.

## DIMENSIONS

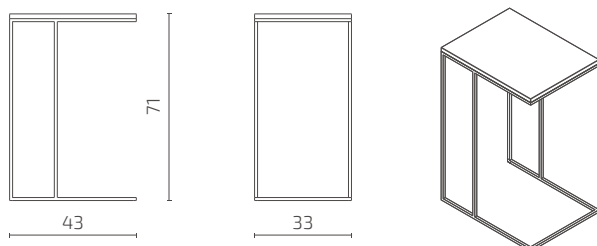

S56-TAB1

All dimensions provided in centimetres.



# Grow

## Mobile plant divider

Design: Lauri Visnapuu

Transform the office into a lush forest and show your commitment to employee well-being. Grow's flowerpots of three different heights act as smart space dividers, offering a secluded retreat from the endlessness of the open office floor plan. Equipped with 360-degree rotating wheels, these planters allow you to refresh the office landscape with a new floral arrangement at your whim.

For added versatility, Grow absorbs office noise and fosters a tranquil environment for the team. Alternatively, choose a multifunctional design featuring a spacious shelf on one side, blending utility with natural beauty.

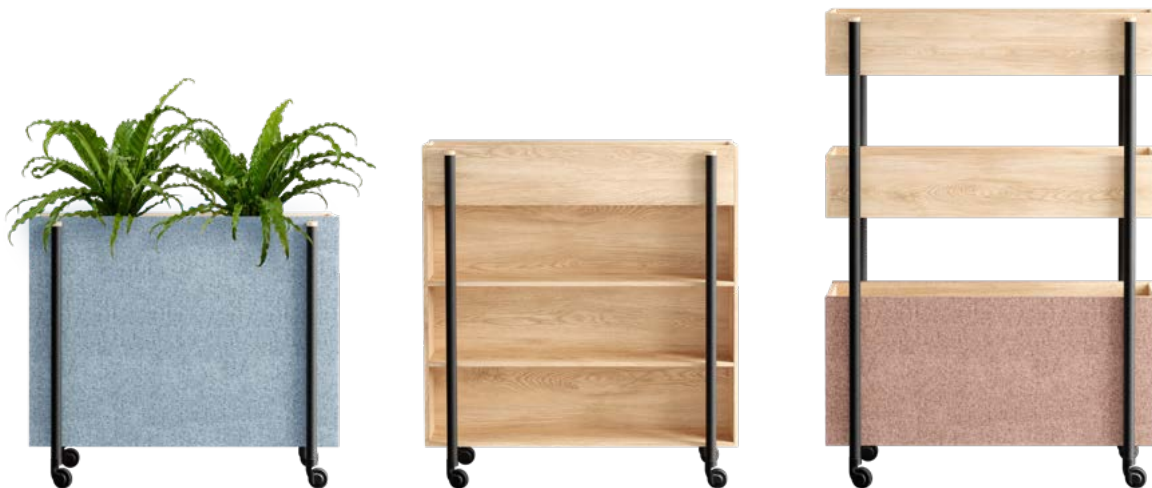

Welcome Zone



Social Zone



Collaboration Zone



Concentration Zone

Construct inspiring private spaces

Improve office acoustics

Bring greenery into the office

## PRODUCT INFORMATION

### Versions

Available in 3 different heights

### Acoustics

Sound absorption class D

### Legs

360° rotating and lockable castors

### Warranty

5 years

### Sustainability

Based on principles of the circular economy

### Test & Certification

Acoustic absorption test - Class D



## STANDARD MATERIALS

### Walls

Veneered MDF board, covered with fabric from one or both sides upon request

### Shelving (on models with shelves)

Veneered MDF board

### Legs

Powder-coated metal

### Plant box

Powder coated waterproof steel

### Fabric upholstery

Choose any fabric from **Intuit Standard Fabric Collection**

### Additional information

As part of after-sales service we offer the change of cover fabric and all other components if needed

Swedbank Eesti in Tallinn, Estonia. Photo: Helis Mahmastol



**The top part of Grow features**  
an integrated waterproof metal box for  
safe watering of plants.



PROTECTIVE  
WATERPROOF  
METAL BOX

## FINISHING OPTIONS

### Shelving and walls

#### *Veneered MDF board*

Natural oak



### Legs

#### *Powder-coated metal*

Jet Black RAL 9005



Other finishing options available on request.



## DIMENSIONS

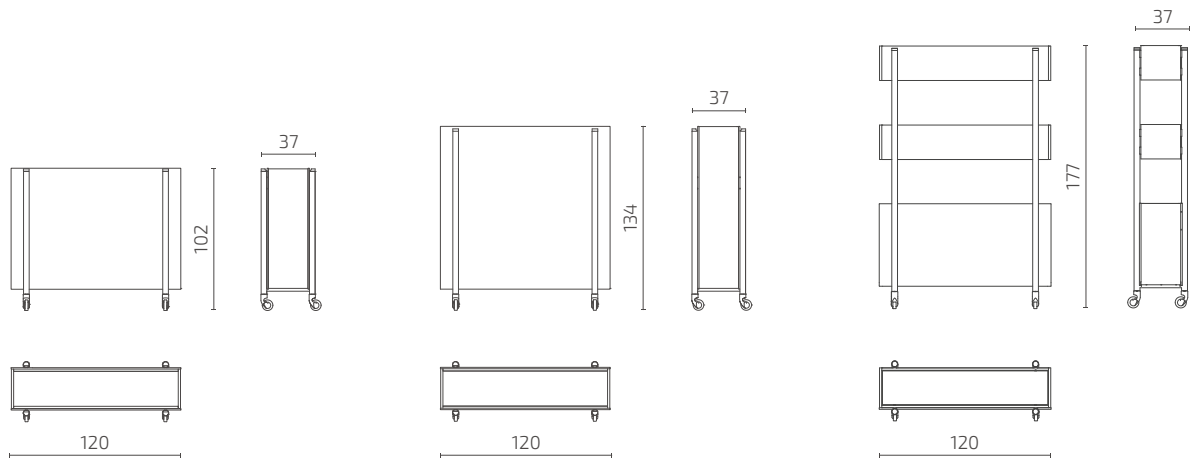

**S123-RJH2**

**S123-RJH3**

**S123-RJH4**

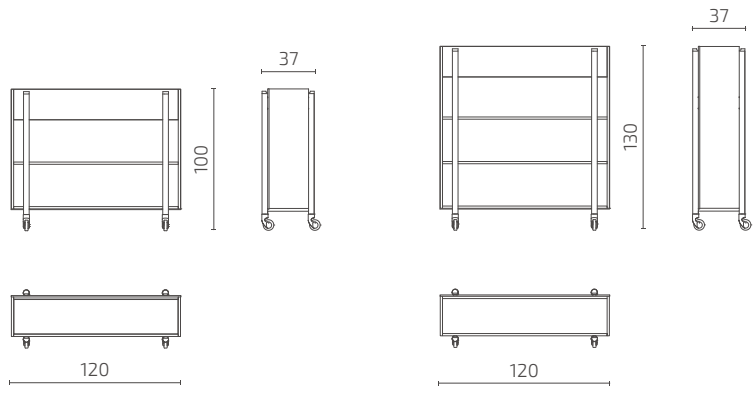

**S123-RJRH2**

**S123-RJRH3**

All dimensions provided in centimetres.



# Hover

## Leaning wall

Design: Karl Kukuk

Sometimes, there's not enough space for a comfortable sofa, but you still want to make waiting comfortable. The day is saved by the soft leaning wall Hover, which you can lean on to pass the time alone or chatting with a companion.

Hover is brilliantly space-saving and fits perfectly in places where you might need to stand, such as at the airport, in a corridor, or behind a meeting room door. Placed in the office kitchen or in an

in-between space, it provides a convenient spot for exchanging ideas with a colleague on the go. Hover is available as a module in four different sizes. By adding a coffee table and a power socket, you can even get work done while leaning. Quickly installable and featuring easily replaceable fabric, Hover also offers noise-dampening properties thanks to its foam and perforated inner panel. Hover is designed for disassembly fully embracing the principles of circular design.

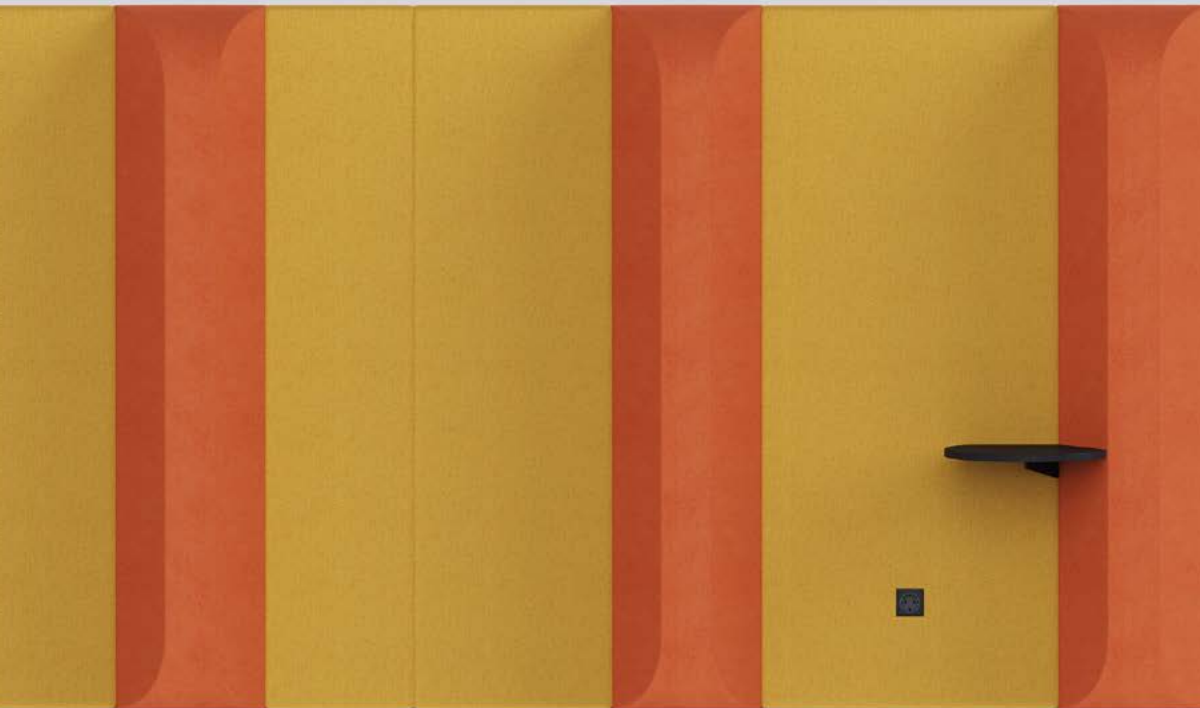

Welcome Zone



Social Zone

Enable to have quick conversations

Save space, adding cosiness to the milieu

Help make waiting more comfortable

## PRODUCT INFORMATION

### Versions

Available in 4 different modules

### Acoustics

Sound absorption class B

### Accessories

Tables to add functionality to the standing area

### Electrical outlet

Intergrated electrical outlet

### Warranty

5 years

### Sustainability

Embraces the principles of circular design

### Test & Certification

Acoustic absorption test - Class B



## STANDARD MATERIALS

### Frame

Solid wood slats, perforated MDF-plate

### Mounting

Metal profiles, button-fix

### Backrest

Durable HR foam; fire retardant HR foam on request

### Tables

Mass-colored wood fibreboard top

### Fabric upholstery

The cover fabric is removable

Choose any fabric from **Intuit Standard Fabric Collection**

### Additional information

As part of after-sales service we offer the change of cover fabric and all other components if needed



## CIRCULAR DESIGN

Designed for disassembly fully embracing **the principles of circular design.**

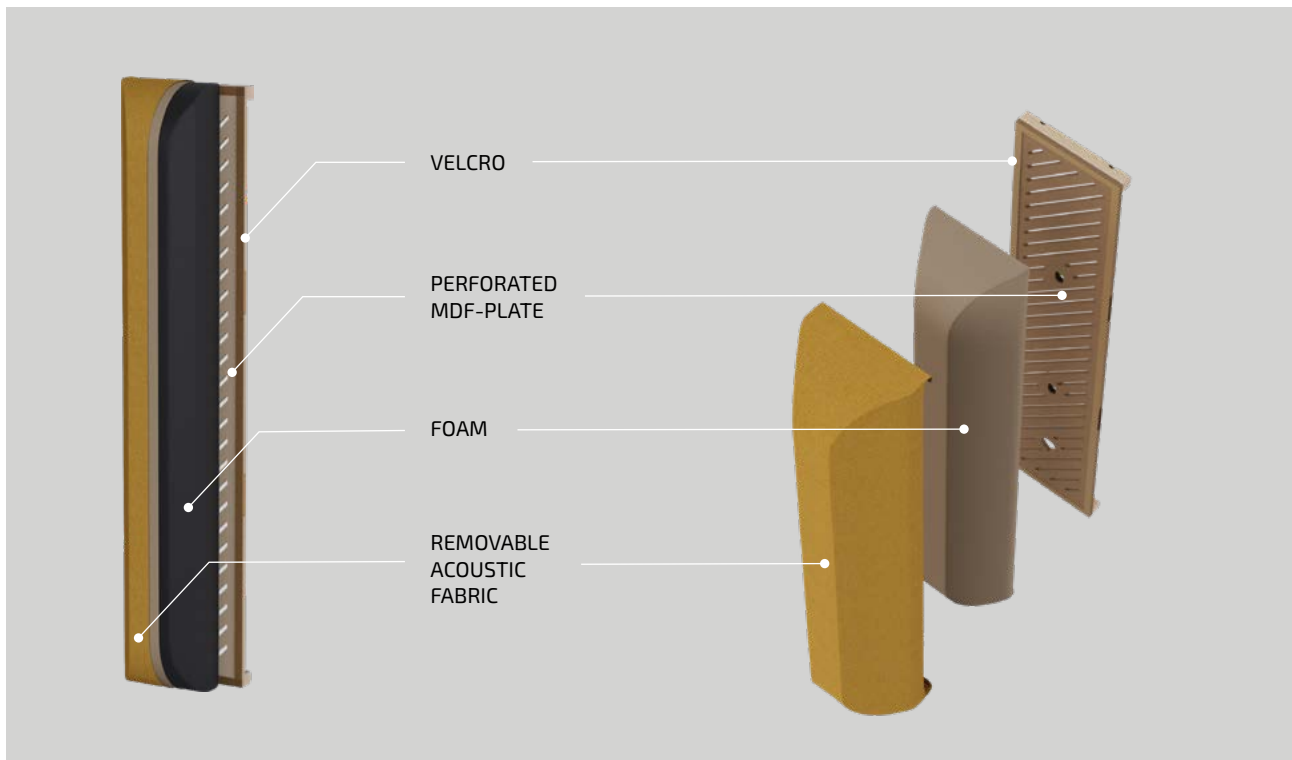

## FINISHING OPTIONS

### Table

#### Mass-colored wood fibreboard

Grey



Black



Other finishing options available on request.



## ELECTRICAL OUTLET



**Berker Integro Flow**  
Color: Anthracite Matt

Available options DK, EU, FR, UK

**220V**



**Berker Integro Flow**  
Color: Anthracite Matt

Available options DK, EU, FR, UK

**USB A & C**

Other electrical outlet combinations available on request.

## DIMENSIONS

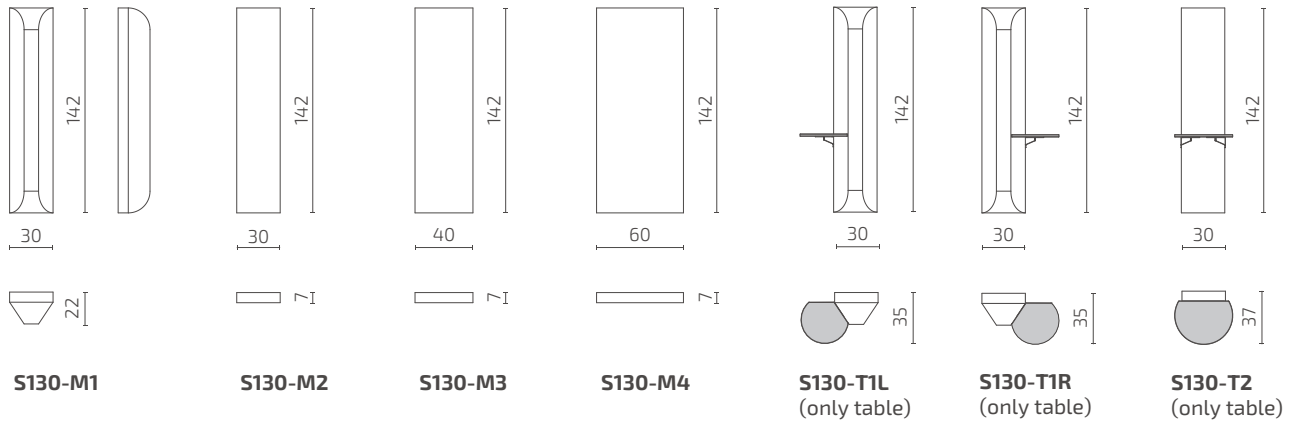

All dimensions provided in centimetres.

## SAMPLE COMBINATIONS



# Note

## Mobile whiteboard

Design: Lauri Visnapuu

Make room for big ideas. Use our convenient mobile whiteboard to utilise every brainstorming opportunity. Equipped with 360-degree wheels, you can take the whiteboard wherever fresh ideas are born.

The back of the whiteboard is optionally covered with cutting-edge acoustic felt. Given its sound-absorbing qualities and notable height, the board can be transformed into a privacy screen, showcasing our love for multifunctional furniture.



Collaboration Zone



Concentration Zone

Minimize workplace noise

Divide your office on the go

Wheel the board around for creative collaboration

## PRODUCT INFORMATION

### Warranty

5 years

### Legs

360° rotating and lockable castors

### Sustainability

Based on principles of the circular economy

### Certification



## FINISHING OPTIONS

### Legs

#### **Powder-coated metal**

Jet Black RAL 9005



Other finishing options available on request.

## DIMENSIONS

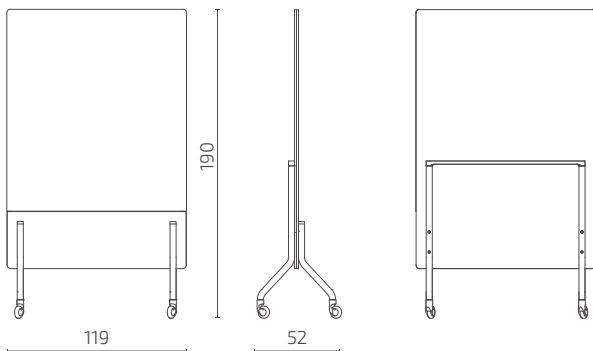

**S124-MWH190**

All dimensions provided in centimetres.

## STANDARD MATERIALS

### Whiteboard

High-pressure decorative laminate

### Panel

MDF, upholstered with batting and covered with acoustic felt on request

### Legs

Powder-coated metal

### Marker Holder

Varnished solid oak

### Fabric upholstery

The cover fabric is not removable

Choose any fabric from **Intuit Standard Fabric Collection**

### Additional information

As part of after-sales service we offer the change of cover fabric and all other components if needed



# Silent Note

## Mobile room divider

Design: Lauri Visnapuu

Shape your world the way you want it. Use this mobile room divider to create a separate space in an open office exactly where you need it. Equipped with 360-degree rotating wheels, it moves easily to the work rhythm of your team.

Silent Note belongs to the Note product family and comes covered with fabric on both sides, offering unlimited possibilities for its unique design. To increase the sound absorbing properties, we recommend using an acoustic felt as a cover.



Collaboration Zone



Concentration Zone

Minimize workplace noise

Divide your office on the go

Wheel the room divider around for creative collaboration

## PRODUCT INFORMATION

### Warranty

5 years

### Legs

360° rotating and lockable castors

### Sustainability

Based on principles of the circular economy

### Certification



## STANDARD MATERIALS

### Panel

MDF, upholstered with batting and covered with acoustic felt on request

### Legs

Powder-coated metal

### Fabric upholstery

The cover fabric is not removable

Choose any fabric from **Intuit Standard Fabric Collection**

### Additional information

As part of after-sales service we offer the change of cover fabric and all other components if needed

## FINISHING OPTIONS

### Legs

#### *Powder-coated metal*

Jet Black RAL 9005



Other finishing options available on request.



## DIMENSIONS

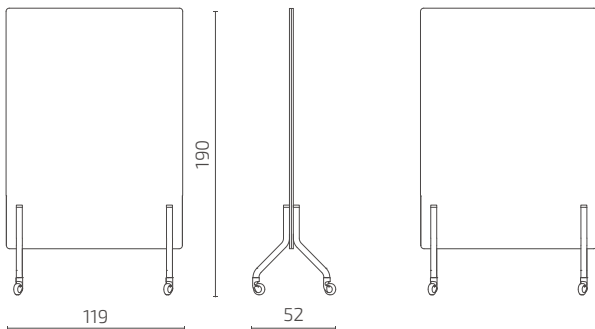

### S124-WH190

All dimensions provided in centimetres.

# Oaas

## Planter room divider

Design: Lauri Visnapuu

Character lies in the details. The small, seemingly insignificant elements that give a space its unique identity. The best details don't just enhance aesthetics – they add value!

The Oaas decorative room divider is a stylish and functional backdrop that brightens any room, regardless of size. Its elegant round modules can stand alone or be connected to form 'walls', creating purposeful zones within a space. Designed with practicality in mind, Oaas features a surface perfect for displaying plants or decorative objects. Plus, its fabric-covered outer wall improves acoustics by absorbing echoes.



Welcome Zone



Social Zone



Collaboration Zone



Concentration Zone

Allow the room to be divided into zones

Reduce noise and echoes

Add variety to the room

## PRODUCT INFORMATION

### Versions

Available as a surface or plant pedestal modules in 7 different heights

### Modularity

Modules can be connected together

### Warranty

5 years

### Sustainability

Based on principles of circular economy

### Certification



## STANDARD MATERIALS

### Frame

MDF, carton

### Sole

Felt sole

### Surfaces

Mass-colored wood fibreboard top

### Inside plant pedestals

Water and dirt retardant vinyl fabric, recycled from our production leftovers

### Fabric upholstery

The cover fabric is removable

Choose any felt from **Intuit felt selection**

### Additional information

As part of after-sales service we offer the change of cover fabric and all other components if needed



## FINISHING OPTIONS

### Surface

#### *Mass-colored wood fibreboard*

Black



Other finishing options available on request.



# SAMPLE COMBINATIONS

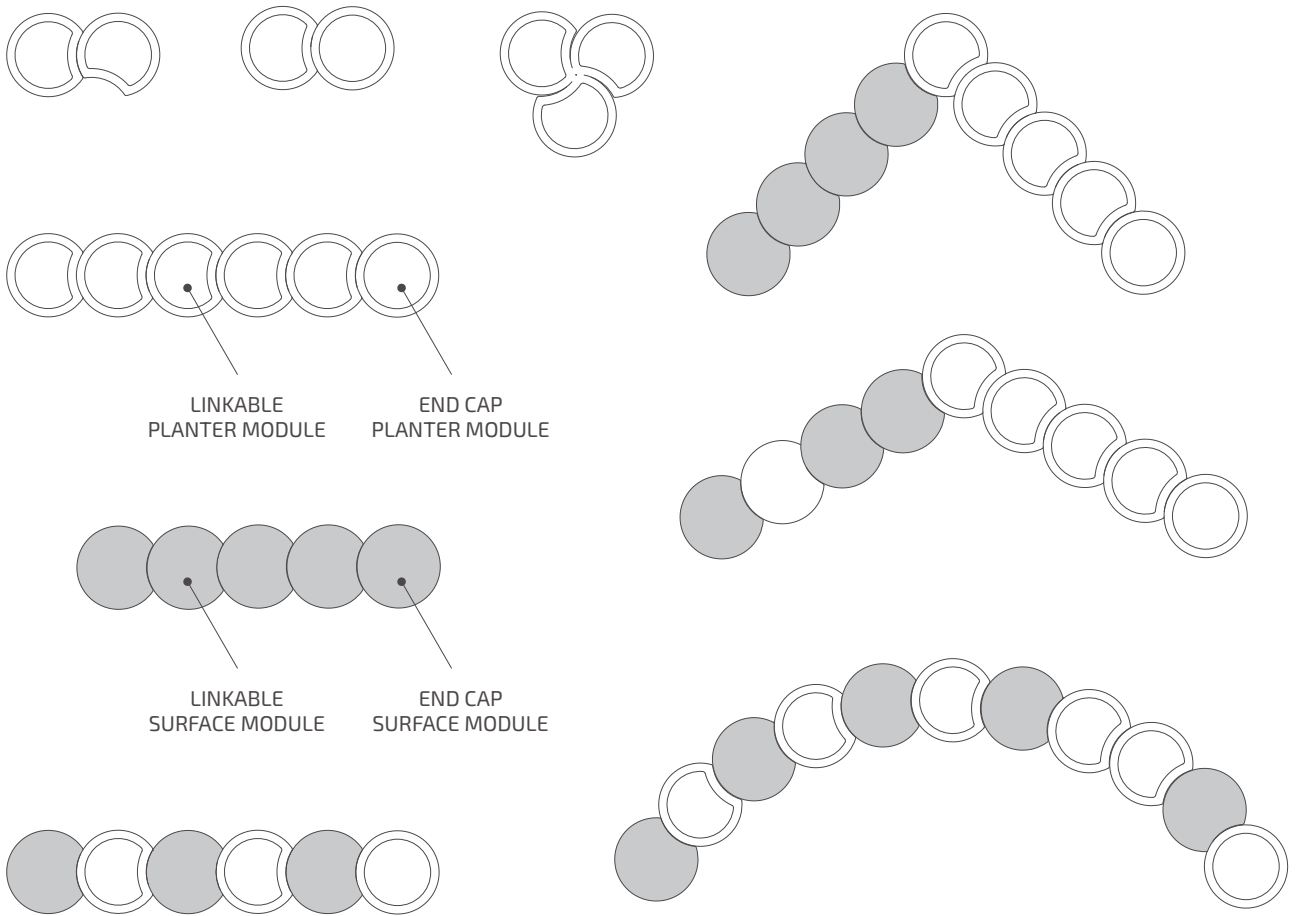

## DIMENSIONS

### Linkable surface module

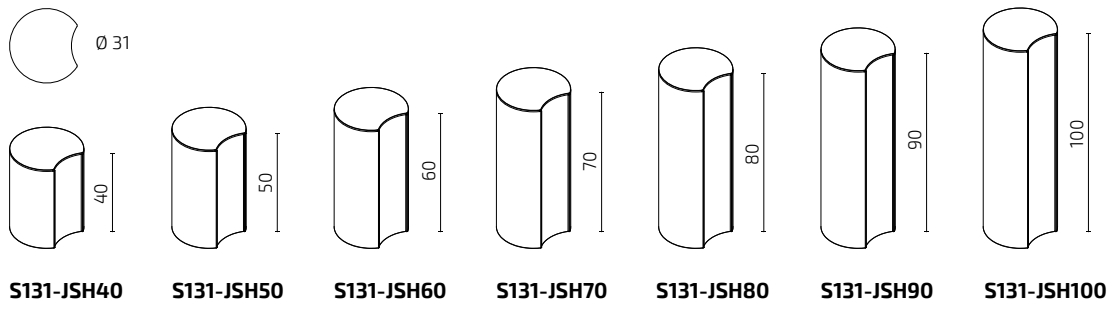

### Linkable planter module

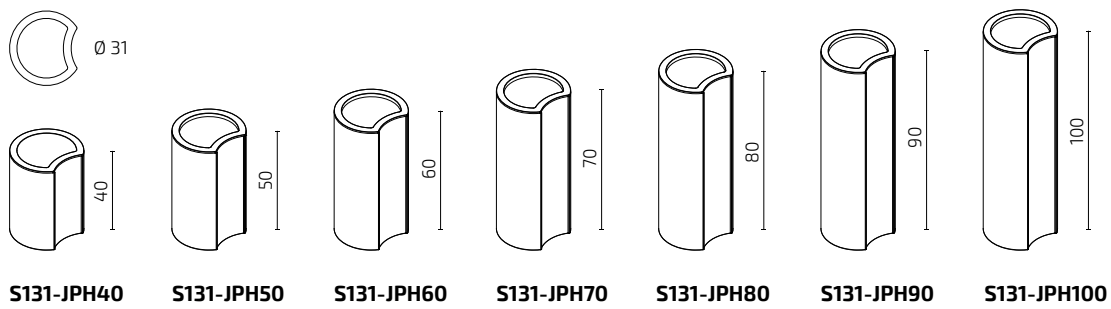

### End cap surface module

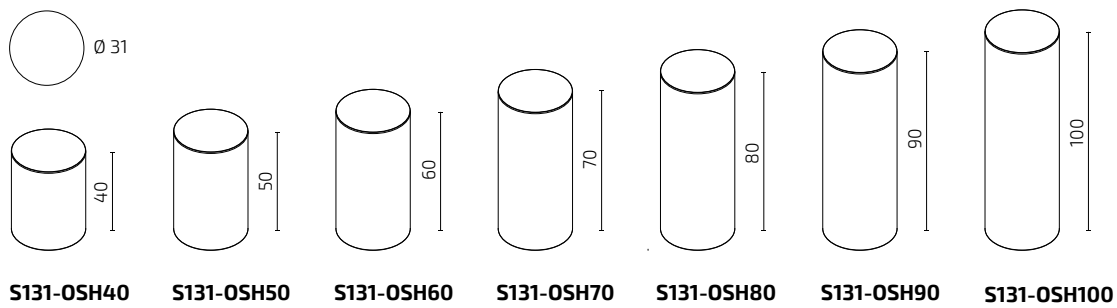

### End cap planter module

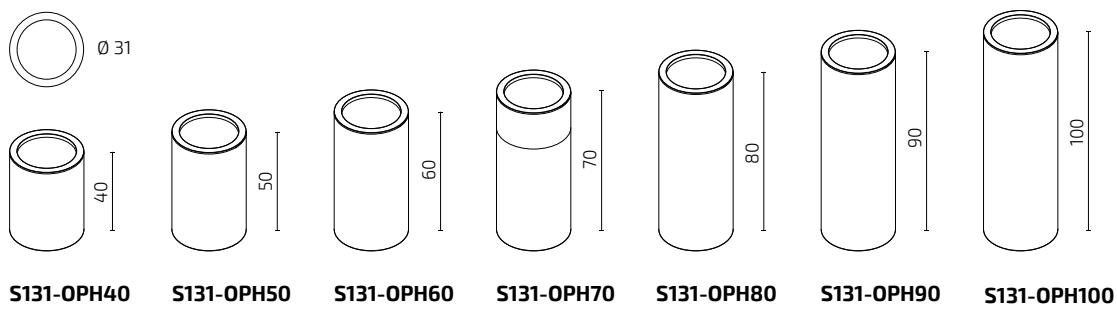

All dimensions provided in centimetres.

**Planter box inner dimensions**

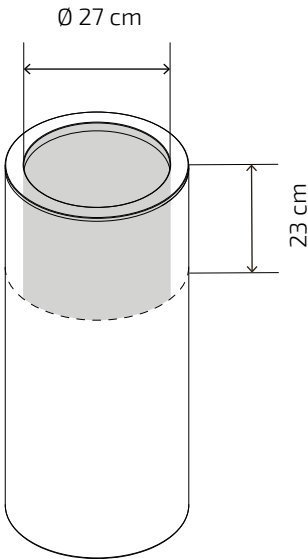

# Sigmund

## Sound-absorbing screen

Design: Pent Talvet, Iseasi

The office of the future is agile and flexible. When you need to change the use of a space without knocking down walls, then you need Sigmund. This ingenious sound-absorbing screen can make any area feel like a private office.

Create a smaller Collaboration Zone within an open-plan space, or curate an enclosed seating area. Wherever the flow of your workplace, Sigmund can help you intuitively meet the needs of your team. Without having to don a hard hat.



Social Zone



Collaboration Zone



Concentration Zone

Easily display information

Deal with background noise

Create a quiet corner

Divide your open space

## PRODUCT INFORMATION

### Warranty

5 years

### Legs

360° rotating wheels

### Sustainability

Based on principles of the circular economy

### Certification



## STANDARD MATERIALS

### Filling

Synthetic felt with sound-absorbing qualities; cotton batting; HR-foam

### Fabric upholstery

The cover fabric is not removable

Choose any fabric from **Intuit Standard Fabric Collection**

### Additional information

As part of after-sales service we offer the change of cover fabric and all other components if needed

## DIMENSIONS

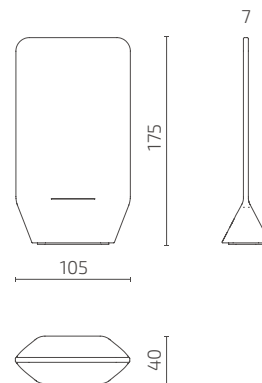

**S104-WH175**

All dimensions provided in centimetres.



# Sprout

## Mobile plant divider

Design: Lauri Visnapuu

Adding greenery to a space enhances overall wellbeing and helps boost productivity. Use the practical Sprout space divider, which lets you grow suitable plants right inside it.

Sprout is ideal for making any space more visually appealing and cosy. Use it to define work areas or leave it in communal spaces for flexible use – Sprout's wheels make it easy to move it around. Sprout is precisely sized to fit between two opposite-facing desks, covering the full span of both workstations and providing privacy. It comes in two heights with three different top surfaces. The fabric-covered exterior adds character and improves room acoustics.



Welcome Zone



Social Zone



Collaboration Zone



Concentration Zone

Easy to move and reposition as needed

Divide the room into zones

Add greenery, cosiness, and a sense of privacy

## PRODUCT INFORMATION

### Versions

Available with 3 different surface widths and in 2 different heights

### Legs

360° rotating and lockable castors

### Warranty

5 years

### Sustainability

Based on principles of circular economy

### Certification



## STANDARD MATERIALS

### Frame

Sheet metal, plywood

### Surfaces

Mass-colored wood fibreboard top

### Planter box

Powder coated waterproof sheet metal

### Fabric upholstery

Choose any felt from **Intuit felt selection**

### Additional information

As part of after-sales service we offer the change of cover fabric and all other components if needed



## FINISHING OPTIONS

### Surface

#### *Mass-colored wood fibreboard*

Black



Other finishing options available on request.



## DIFFERENT SURFACES

### NARROW SURFACE

The most compact option. With minimal surface space around the planting area, this version is perfect for use in narrow corridors and passageways.

### EXTENDED SURFACE

The medium-width surface surrounding the planting area is complemented by an extra surface. It can be used for seating or storing work equipment. Suitable for both open areas and between desks.

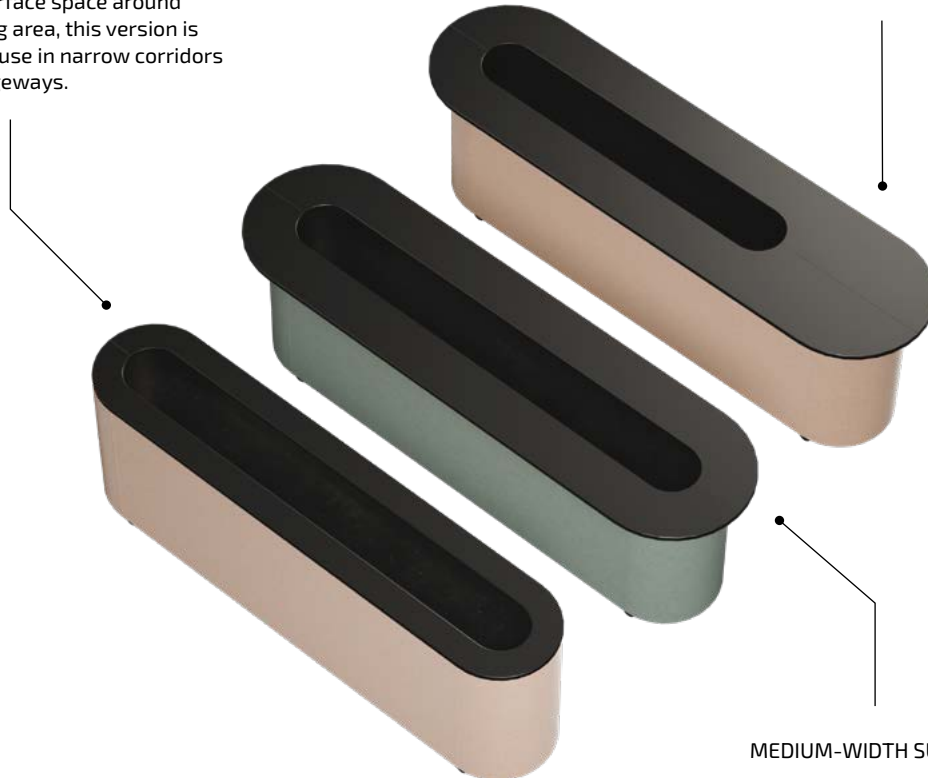

### MEDIUM-WIDTH SURFACE

The planting area is bordered by a medium-width surface – ideal for resting small items like a coffee cup. Suitable for placement in the centre of a room, where it creates visual separation.

## DIMENSIONS

### Narrow surface

#### Planter box inner dimensions

Width: 150 cm / Depth: 31 cm / Height: 22 cm

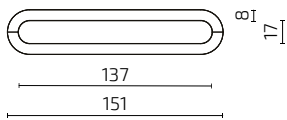
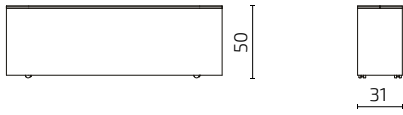

**S78-V1H1**

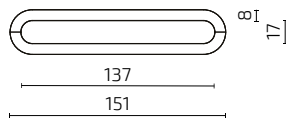
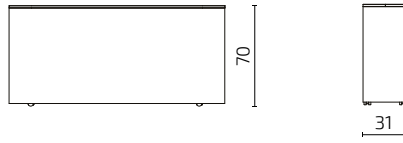

**S78-V1H2**

### Medium-width surface

#### Planter box inner dimensions

Width: 150 cm / Depth: 31 cm / Height: 22 cm

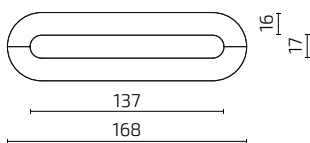
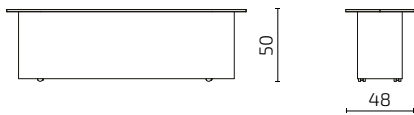

**S78-V2H1**

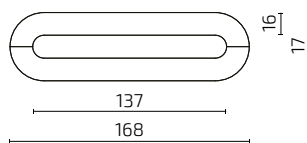
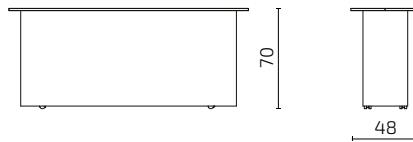

**S78-V2H2**

### Extended surface

#### Planter box inner dimensions

Width: 150 cm / Depth: 31 cm / Height: 22 cm

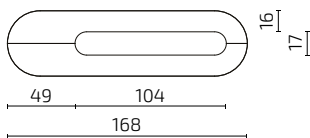
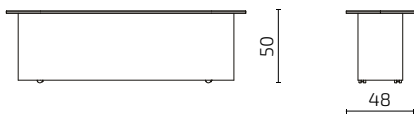

**S78-V3H1**

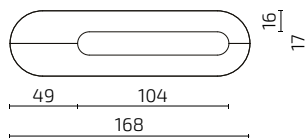
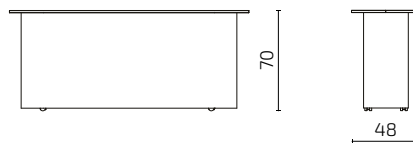

**S78-V3H2**

All dimensions provided in centimetres.

# STANDARD FABRIC COLLECTION: A SYMPHONY OF DESIGN, DURABILITY AND SUSTAINABILITY

At Intuit by Softrend, we understand that the right fabric can transform a piece of furniture from merely functional to truly exceptional. That's why we offer an extensive Standard Fabric Collection, featuring over 1,000 high-quality fabrics sourced from renowned international suppliers including Camira, Kvadrat, Gabriel, and others. Each fabric is carefully selected to ensure it meets the rigorous demands of public spaces, with superior durability and compliance with flame and/or fire resistance standards.

Our collection is meticulously curated to cater to diverse tastes and budgets, organized into five distinct price categories. This structured assortment ensures that whether you're seeking luxury or affordability, you'll find fabrics that do not compromise on quality or style.

For those who desire a personal touch, we offer the flexibility to upholster your chosen furniture with your own material, allowing for a truly customized interior experience.

We are committed to sustainability; the majority of our fabrics bear the Oeko-Tex or Ecolabel certifications and/or are made from recycled materials, reflecting our dedication to environmental responsibility. Our annual update of the fabric selection not only aligns with the latest trends but also retains beloved classics that have stood the test of time.





Discover fabrics ranging from rich wools and sleek artificial leathers to soft felts, most backed by a 10-year manufacturer's warranty. The Intuit by Softrend Standard Fabric Collection is designed not just to meet, but to exceed the functional and aesthetic needs of any space.





# STANDARD FABRICS SELECTION 2026

## PRICE CATEGORY 1

Brand	Design	Martindale	Composition	Flammability standard				Sustainability	Other
				EN 1021 1 & 2	BS 5852		IMO		
					Part 1 0 & 1	Part 2 5 Crib			
Camira	<a href="#">Era CSE</a> 01, 02, 21, 25, 31, 32, 34, 39, 41, 42	100 000	100% polyester	X		X		 10 YEAR	
Davis	<a href="#">Cloud</a>	90 000	100% polyester	Part 1 only	X				
Davis	<a href="#">Storm</a>	100 000	100% polyester	Part 1 only	X				
Nevotex	<a href="#">Lido/Lido</a> <a href="#">Trend</a>	115 000	100% polyester	Part 1 only	X				
Textum	<a href="#">Lotos</a>	100 000	80% PES 20% CO base fabric 100% PU surface		X				



Recycled fabric



Easy-clean fabric



Faux leather



Acoustic fabric



10 year guarantee



























Water repellent



Easy-water cleaning

## PRICE CATEGORY 2

Brand	Design	Martindale	Composition	Flammability standard				Sustainability	Other
				EN 1021 1 & 2	BS 5852		IMO		
					Part 1 0 & 1	Part 2 5 Crib			
Blue Company	<a href="#">Dama</a>	> 60 000	70% wool 20% polyester 5% polyamide 5% acrylic (recycled wool)	X	X	X			
Camira	<a href="#">Era*</a>	100 000	100% polyester	X		X			10 YEAR
Camira	<a href="#">Vita</a>	100 000	Surface: 98% PVC 2% PU Substrate: 100% cotton	X		X	On request		
Camira	<a href="#">RePlay</a>	100 000	100% post-consumer recycled polyester	X		X		  	10 YEAR
Camira	<a href="#">X2</a>	100 000	100% recycled polyester	X		X		  	10 YEAR
Fabraa	<a href="#">Facet</a>	100 000	70% recycled wool 25% polyamide 5% blended fibre	X	X				
Fabraa	<a href="#">Forward</a>	100 000	50% recycled wool 30% linen 20% recycled polyamide	X	X				
Gabriel	<a href="#">Cura</a>	100 000	98% post-consumer recycled polyester 2% polyester	X	X			  	10 YEAR
Kvadrat	<a href="#">Autumn</a>	50 000	100% recycled polyester	X	X	X		 	10 YEAR
Kvadrat	<a href="#">Guest</a>	100 000	100% recycled polyester	X	X	X		 	10 YEAR
Nevotex	<a href="#">Wooly</a>	150 000	70% recycled wool 25% polyamide 5% blended fibre	X	X				
Textafoam	<a href="#">Aston</a>	70 000	100% polyester		X				

\* Except the fabric tones listed in Price category 1

## PRICE CATEGORY 3

Brand	Design	Martindale	Composition	Flammability standard				Sustainability	Other
				EN 1021 1 & 2	BS 5852		IMO		
					Part 1 0 & 1	Part 2 5 Crib			
AquaClean	<a href="#">Daytona</a>	200 000	51% polyester 38% acrylic 11% polyamide	X	X				
Camira	<a href="#">Main Line Flax</a>	50 000	70% virgin wool 30% flax	X		X	On request		10 YEAR
Camira	<a href="#">Main Line Twist</a>	50 000	75% virgin wool 30% flax	X		X			10 YEAR
Camira	<a href="#">Oceanic</a>	100 000	100% post-consumer recycled polyester excl. 50% SEAQUAL® YARN	X		X			10 YEAR
Camira	<a href="#">Sumi</a>	200 000	90% wool 10% polyamide	X		X	On request		10 YEAR
Gabriel	<a href="#">Step Melange</a>	100 000	100% Trevira CS	X	X	X			10 YEAR
Kvadrat	<a href="#">Remix 3</a>	100 000	90% new wool worsted 10% nylon		X	X			10 YEAR
Spradling	<a href="#">Silvertex</a>	300 000	100% vinyl topcoat 100% polyester backing	X					



Recycled fabric



Easy-clean fabric



Faux leather



Acoustic fabric



10 year guarantee











Water repellent







Easy-water cleaning

## PRICE CATEGORY 4

Brand	Design	Martindale	Composition	Flammability standard				Sustainability	Other
				EN 1021 1 & 2	BS 5852		IMO		
					Part 1 0 & 1	Part 2 5 Crib			
Camira	<a href="#">Kyoto</a>	200 000	90% wool 10% polyamide	X		X	On request		10 YEAR
Camira	<a href="#">Synergy</a>	100 000	95% virgin wool 10% polyamide	X		X	On request		10 YEAR
Gabriel	<a href="#">Fame</a>	200 000	95% New Zealand wool 5% polyamide	X		X		 	10 YEAR
Kvadrat	<a href="#">Re-wool 2</a>	100 000	45% recycled wook 45% new wool 10% nylon	X	X	X		 	10 YEAR

## PRICE CATEGORY 5

Brand	Design	Martindale	Composition	Flammability standard				Sustainability	Other
				EN 1021 1 & 2	BS 5852		IMO		
					Part 1 0 & 1	Part 2 5 Crib			
Camira	<a href="#">Blazer</a>	45 000	100% virgin wool	X		X	On request		10 YEAR
Camira	<a href="#">Yoredale</a>	50 000	95% wool 3% polyester 2% polyamide	X		X	On request		10 YEAR
Kvadrat	<a href="#">Canvas 2</a>	100 000	90% new wool worsted 10% nylon	X	X	X			10 YEAR
Kvadrat	<a href="#">Steelcut Trio 3</a>	100 000	90% new wool 10% nylon	X	X				10 YEAR



## Are You Intuit?

 [intuitoffice.com](https://intuitoffice.com)

 [intuit\\_office](#)

 [Intuit by Softrend](#)

 [Intuit by Softrend](#)

Browse the Collection

